

TOWER INTERNALS

HARDWARE AND SERVICES

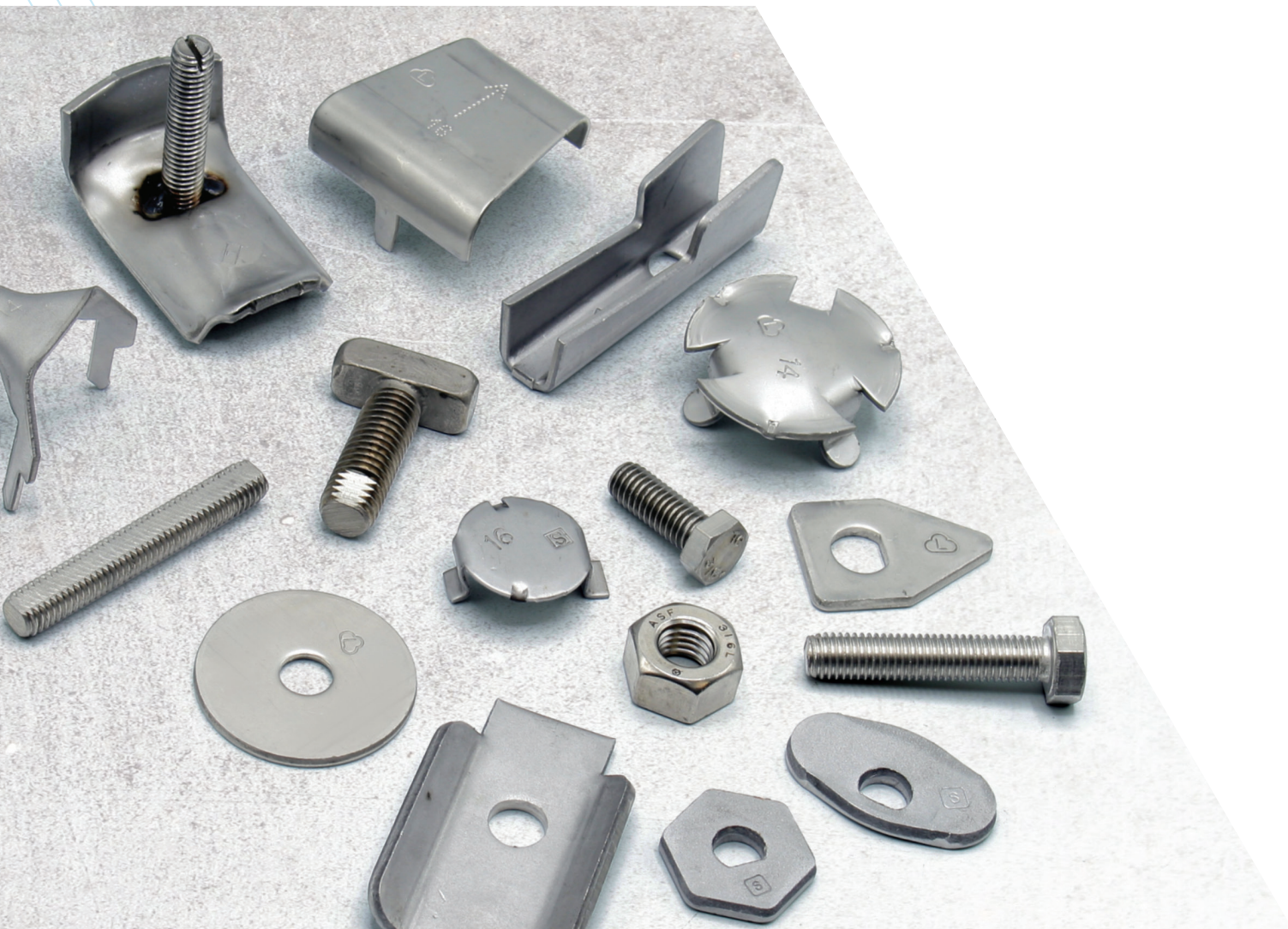

AHOP® AUTOMATED HARDWARE ORDERING PROGRAM

Is it difficult to find old drawings to confirm what you have in your towers? Our AHOP® Automated Hardware Ordering Program can help eliminate tower hardware issues during turnaround service by taking the guesswork out of what is inside your towers.

Our innovative computerized program provides an audit of each of your towers to confirm and document all equipment and hardware. AHOP® automated hardware ordering program is a free research service for turnaround management tailored to each tower for both Koch-Glitsch and non-Koch-Glitsch equipment. Hardware is supplied for your plant turnaround in a secure Koch-Glitsch hardware locker.

AHOP® Automated Hardware Ordering Program:

- ▼ Reduce inventory
- ▼ Expedite equipment orders
- ▼ Simplify planning of turnarounds
- ▼ Provide exactly what is required
- ▼ Only pay for what you use
- ▼ No charge for research
- ▼ Delivered on time

To enroll in the program, contact your local Koch-Glitsch representative or emergency hotline.

Hardware Lockers and Trailers

For unexpected downtimes as well as planned plant turnarounds, Koch-Glitsch can provide a secure hardware locker or trailer filled with the specific hardware items you need for a specific tower. Koch-Glitsch hardware lockers and trailers can come to your site and stay with you during your plant maintenance turnarounds.

- ▼ Tailored to your plant turnaround needs
- ▼ Contains the specific hardware for a specific tower
- ▼ Ensures you pay only for what you use
- ▼ Available when you need it
- ▼ Reduces unnecessary hot-shot delivery charges



FIELD SERVICES

ONE-SOURCE SOLUTION and Field Installation Services

Correct installation is critical to achieve the maximum benefit from today's high-performance equipment. The ONE-SOURCE SOLUTION approach integrates the design and fabrication of Koch-Glitsch's unique technologies with value-driven installation solutions and turnaround management from Koch Specialty Plant Services LLC (KSPS). The end result is an optimized installation that is safer, faster and more cost effective for column revamps or new construction.

The project delivery system emphasizes pre-job planning and design and focuses on optimizing equipment performance, constructability and installation efficiency. This often results in shorter duration plant turnarounds, which can create cost savings for customers. Additionally, extensive experience combined with complementary engineering designs and construction technologies provides the flexibility needed to adjust quickly, efficiently and appropriately to project changes and challenging discovery work to avoid extending the schedule for construction turnaround services.

Koch-Glitsch knows it is critical that equipment be installed in a safe and proper manner to provide the customer with the maximum benefit possible for the application. There is no substitute for an experienced, safe, well-trained, and properly supervised installation crew during plant turnarounds, and KSPS offers unmatched capabilities in these areas.

With over 40 years of experience in the refining and petrochemical industries, KSPS provides a comprehensive range of tower services that includes ASME and NBIC code repairs and alterations, specialty welding, vessel section replacement, field-erected vessels, project controls, project management and engineering. From pre-job planning and design through construction and installation, KSPS' focus on safety and efficiency can ensure your equipment is up and running quickly, efficiently and safely, resulting in less down time no matter where you are in the world. For more information on KSPS, please visit kochservices.com.



CERTIFIED TOWER SPECIALIST AND EQUIPMENT SUPPORT SERVICES

For specialized equipment inspection and/or installation expertise, our Certified Tower Specialist (CTS) consultants are available globally to observe and analyze installations from start to finish for added turnaround management.

At your work site, a Koch-Glitsch field technician can inventory equipment, observe and inspect new and replacement equipment installations, assist in evaluating and inspecting existing equipment during plant turnarounds or unplanned outages, be an onsite resource to resolve inquiries to assure equipment is installed to Koch-Glitsch's specifications, and expedite installation and field troubleshooting.

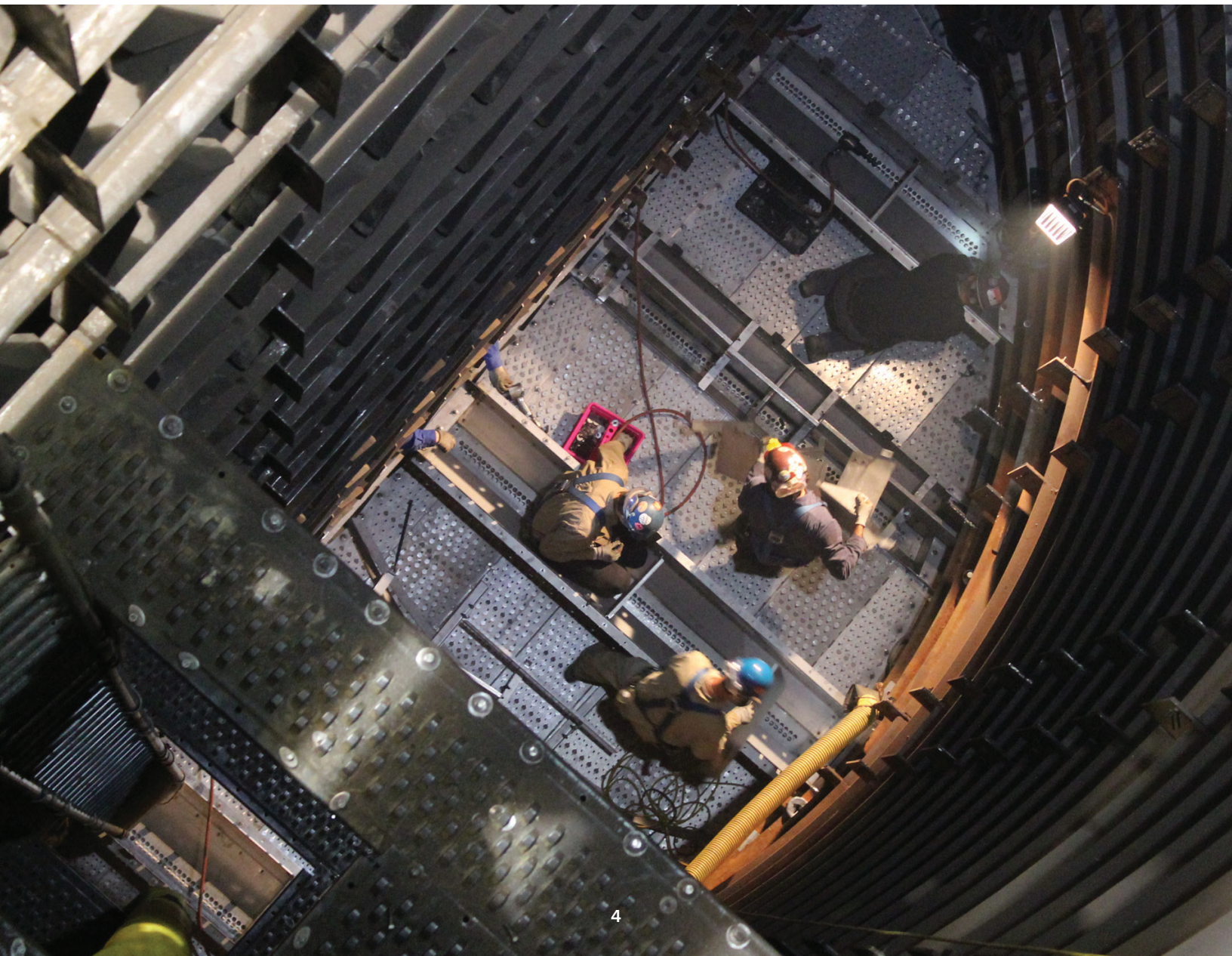

REPLACEMENT EQUIPMENT

While it is important to properly plan for scheduled maintenance and plant turnarounds, sometimes unplanned outages occur. That's where Koch-Glitsch's emergency services excel. Koch-Glitsch stocks common raw materials to allow for cost effective and expedited equipment delivery to get you back on line, regardless of original equipment manufacturer. Make Koch-Glitsch your first call for your planned plant turnarounds or emergency maintenance and repairs. Rush replacement can be provided on full assemblies or on individual components whenever needed. Call the emergency hotline for any replacement or service needs.

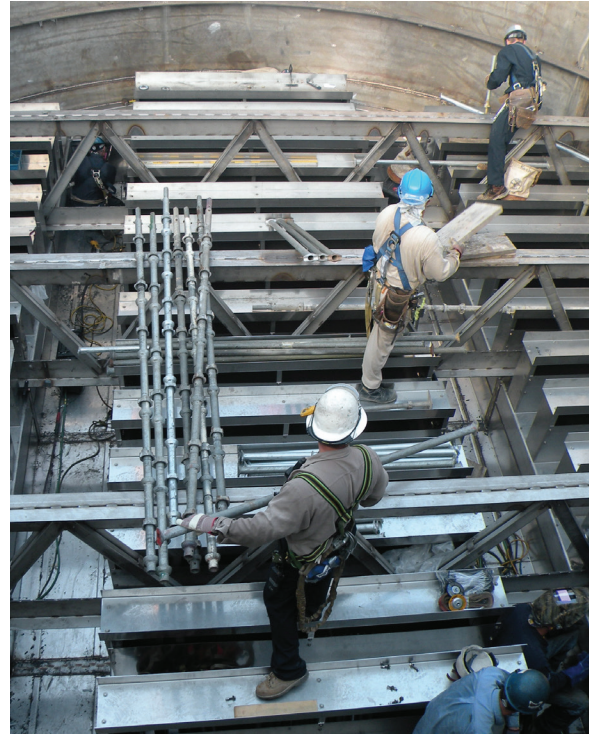

FLEXILOCK® TRAY CONSTRUCTION

This patented tray joint allows rapid installation of tray panels in vessel shops or in the field. FLEXILOCK® tray construction eliminates the requirement for hardware between adjacent tray panels and reduces the potential for errors during installation. FLEXILOCK® tray construction is the primary building block of the HORIZON® technology.

- ▼ Reduce hardware requirements
- ▼ Improve valve coverage
- ▼ Provide error-free deck installation
- ▼ Dramatically reduce installation time
- ▼ Strengthen joint and uplift tolerance
- ▼ Promote in-shop installations
- ▼ Eliminates vibration-induced panel shifting











Material Symbols And Designations

To avoid confusion in identifying and locating the proper material type, Koch-Glitsch die stamps its hardware with specific symbols indicating material analysis. To properly identify each item when ordering, we ask that you insert the proper material type numerical code for the material identification number (MMMM) and the abbreviated material name for the item description (Mat'l). In the example below for a Type 316L, 14 Ga. 1-3/4" Domed Washer, you would insert "361G" in the material identification number (MMMM) and "Ty-316L" into the Item Description (Mat'l).

Threaded items (Bolts, Nuts, Studs, & Rods) are normally supplied in AISI specification/materials. Items are available in ASTM specification/materials on request.

GENERIC METAL TYPE

- **802-MMMM 102**
Insert Material identification number from chart on p. 6.
- **Washer, Domed, Mat'l, 14 Ga, 7/16" id x 1-3/4" OD.**
Insert abbreviated Material name from p. 6.

Stamped Name	Material Ident. (MMMM)	Abbreviated Name (Mat'l)	Common Name	Stamped Name	Material Ident. (MMMM)	Abbreviated Name (Mat'l)	Common Name
	100G	C.S.	Carbon Steel*		117G	Copper Silicon	Copper Silicon
	410G	Ty-410S	Type 410S Stainless Steel*	EB	261G	E-Brite	E-Brite
	304G	Ty-304	Type 304 Stainless Steel	HB	864G	Hast. B	Hastelloy B-2
	340G	Ty-304L	Type 304L Stainless Steel*	HC	861G	Hast. C	Hastelloy C-276
	316G	Ty-316	Type 316 Stainless Steel	HF	868G	Hast. F	Hastelloy F
	361G	Ty-361L	Type 316L Stainless Steel*	HG	866G	Hast. G	Hastelloy G-30
	317G	Ty-317	Type 317 Stainless Steel		830G	Inconel 600	Inconel 600
	371G	Ty-317L	Type 317L Stainless Steel		625G	Inconel 625	Inconel 625
	321G	Ty-321	Type 321 Stainless Steel		820G	Incoloy 800	Incoloy 800
	347G	Ty-347	Type 347 Stainless Steel		870G	Incoloy 825	Incoloy 825
	904G	Ty-904L	Type 904L Stainless Steel		675G	Nickel	Nickel
	301G	AL-6XN	AL-6XN		600G	Monel	Monel*
	205G	2205	2205	T2	516G	Ti-Gr2	Titanium Grade 2
	840G	Alloy 20	Alloy 20 (Carpenter 20)	T7	520G	Ti-Gr7	Titanium Grade
A3	121G	Alum 3003	Aluminum 3003	Z2	502G	Zirc. 702	7 Zirconium 702
A6	119G	Alum 6061	Aluminum 6061	Z5	505G	Zirc. 705	Zirconium 705
	116G	Copr Deox	Copper Deoxide		860G	Hast. C22	Hastelloy C22
S	635G	254 SMO	254 SMO	A5	122G	Alum 5052	Aluminum 5052
	310G	Ty-310S	Type 310 Stainless Steel		118G	AL. Bronze	Aluminum Bronze
	430G	Ty-430	Type 430 Stainless Steel		115G	Everdur	Silicon Bronze
F	660G	Ferralium	Ferralium 255				

*These materials are routinely stocked in all regional warehouses.
NOTE: The "G" represents sheet and plate material (fabricated items). In most cases, for threaded items the material code for bolts, studs, rods and nuts will have the letter "F" (340F).

ASSEMBLY REFERENCE GUIDE

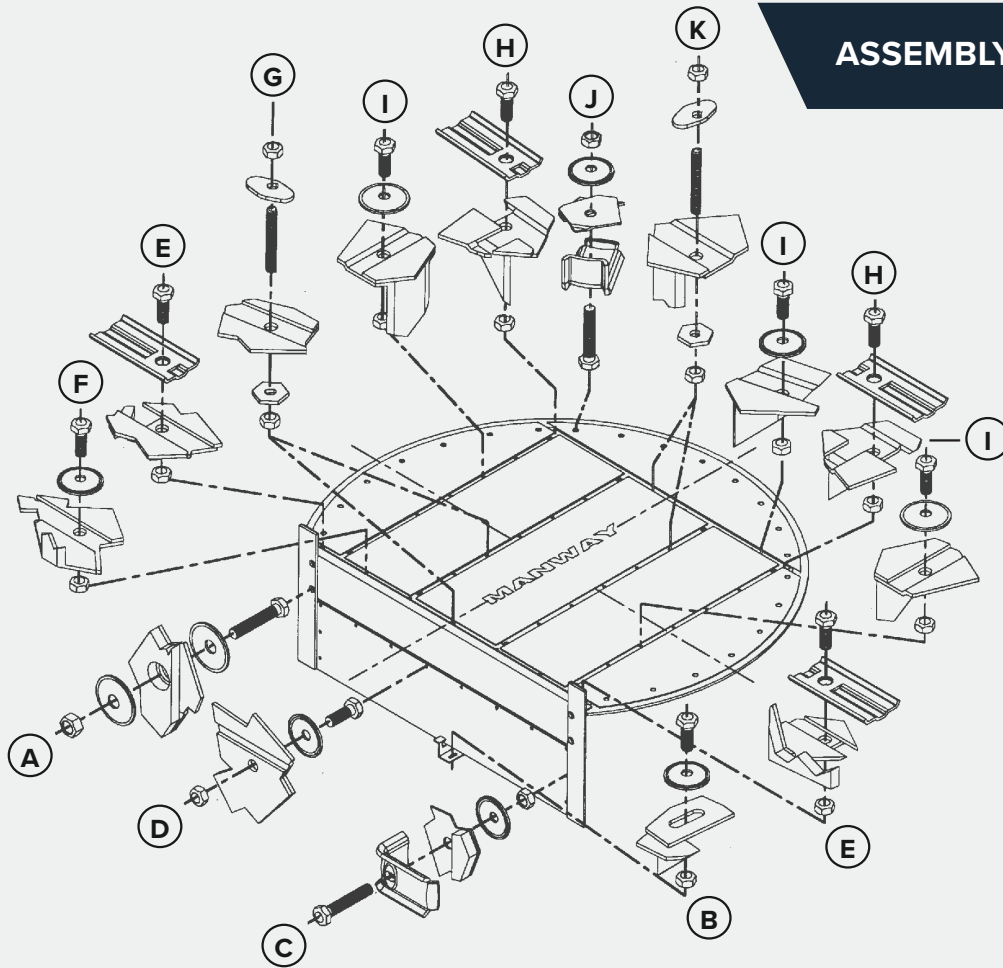

ASSEMBLIES	COMPONENTS	PAGE NO.
A, B, D, F & I	Hex Nut	9, 32
	Hex Head Bolt	9, 32
	Domed Washer(s)	9, 35

ASSEMBLIES	COMPONENTS	PAGE NO.
C & J	Hex Nut	9, 32
	Hex Head Bolt	9, 32
	BTC "Y"	9, 33
	Domed Washer	9, 35

ASSEMBLIES	COMPONENTS	PAGE NO.
E & H	Hex Nut	9, 32
	Hex Head Bolt	9, 32
	Seal Plate	12, 35

ASSEMBLIES	COMPONENTS	PAGE NO.
G & K	Hex Nuts	9, 32
	Manway Lock Clamps	10, 32
	Manway Lock Stud	11, 33

STANDARD ITEMS	PAGE NO.
Hex Nuts, Hex Head Bolts	9
Washers (Frictional, Domed and Lock)	9
Bottom Tray Clamps Y	9
Bottom Tray Clamps YN and YB	10
Bottom Tray Clamps #50-52	10
Universal Lever Clamps #2	11
Tray Clamps	11
Bottom Tray Clamps YD (Manway)	11
Manway Lock Clamps #2, 3, 20, 45, 70, 584, 951, Manway Clamp #938, Manway Seal Clamps #583, 952	11 – 12
Manway Pointer #75, Manway Lock Studs	12
Tee Bolts (Manway)	12
Seal Plates, Bottom Clamp #5, Single Bar Clamps	13
Friction Plate and Beam Plate	13
Clip Angles and Wedges	13
Gasketing (Washers, Tapes and Ropes)	14
Valves, Caps, PROVALVE® and FLEXITRAY® Caps	15 – 18

NON-STANDARD ITEMS	PAGE NO.
Heavy Hex Nuts, Heavy Hex Head Bolts	19
Carriage Bolts, Washers (Eccentric)	19
Bottom Tray Clamps #53-55	20
Bottom Tray Clamps #50SWN, 50SWB and #EM	21
Bottom Tray Clamps #20 Series	22
Bottom Tray Clamps #10A-10P and 12A-12N	22
Bottom Tray Clamps #7 and 13A-13P	23
Universal Lever Clamps #1 and 3	23
Single Lever Clamps	23
Top Tray Clamps #1 and 2	24
Tray Floor Clamps #L-2 and L-4	24
Bottom Clamps #4, 6, 7, 8, 9 and 12	24
Double Bar Clamps	24
Double Lever Clamps	25
Manway Lock Clamps #30, 40A-40P, 50A-50N, 55, and 65	25 – 26
Manway Lock Clamps #60, 2-K thru 2-V & 3-K thru 3-V, and 4	26
Manway Washer	26
Support Grid Clamp #2	27
Grid Holddown Clip #3, Hook Bolt #1	27
Holddown Plates #1 and 2	27
Angle Hangers #10, 10S, 20 and 20S	27
Top Truss Hangers #6-10 and 12	28
C Clamps #1-7, Type A Washers, Type B Washers	28
Wedges #6 and 10	28
Ballast® Units, V-1, GV-1, and V-4 Series	29
Ballast® Plate and Travel Stop A-1, A-2, and A-4 Series, Orifice Cover A-1	30
Caged Nuts	31
Manway Lock Clamps 2-Way	31

METRIC ITEMS	PAGE NO.
Hex Nuts, Caged Nuts, Hex Head Bolts, Carriage Bolts	32
Manway Lock Clamps #2, 3, 20 and 65	32
Manway Clamps	32
Bent Manway Washers, Manway Lock Studs #5, 7, 10 and 11	33
Bottom Tray Clamps Y and YD (Manway)	33
Bottom Tray Clamps YB and YN	34
Universal Lever Clamps #1 and 3	34
Single Lever Clamps	34
Seal Plates, Washers (Domed and Frictional)	35
Hook Bolt #1, Holddown Plates #1 and 2	35
Angle Hangers #161-163	35

- **891-MMMM 01**
Insert Material identification number from chart on p. 6.
- **Nut, Hex, Mat'l, 3/8"-16 UNC-2B**
Insert abbreviated Material name from p. 6.

STANDARD HARDWARE ITEMS

ITEM NO.	ITEM DESCRIPTION	HEX NUTS	891
891-MMMM 01	Nut, Hex, Mat'l, 3/8"-16 UNC-2B		
891-MMMM 02	Nut, Hex, Mat'l, 1/2"-13 UNC-2B		

Commonly stocked in: C.S., Monel, Ty-304L, Ty-316L and Ty-410. Available in other materials and diameters upon request.

ITEM NO.	ITEM DESCRIPTION	HEX HEAD BOLTS	896
896-MMMM 1104	Bolt, Hex. Head, Mat'l, 3/8"-16 UNC-2A x 1" LG		
896-MMMM 1106	Bolt, Hex. Head, Mat'l, 3/8"-16 UNC-2A x 1-1/2" LG		
896-MMMM 1108	Bolt, Hex. Head, Mat'l, 3/8"-16 UNC-2A 2" LG		
896-MMMM 1112	Bolt, Hex. Head, Mat'l, 3/8"-16 UNC-2A x 3" LG		
896-MMMM 0106	* Bolt, Hex. Head, Mat'l, 1/2"-13 UNC-2A x 1-1/2" LG		
896-MMMM 0108	Bolt, Hex. Head, Mat'l, 1/2"-13 UNC-2A x 2" LG		

**Stocked in: C.S., Ty-304L, Ty-316L and Ty-410.
Commonly stocked in: C.S., Monel, Ty-304L, Ty-316L and Ty-410. Available in other materials and sizes upon request.*

ITEM NO.	ITEM DESCRIPTION	FRICTIONAL WASHERS	800
800-MMMM 010801	Washer, Frictional, Mat'l, 14 Ga, 7/16" id x 1" od		
800-MMMM 030801	* Washer, Frictional, Mat'l, 10 Ga, 7/16" id x 1" od		
800-MMMM 020101	Washer, Frictional, Mat'l, 12 Ga, 7/16" id x 1-1/2" od		
800-MMMM 030101	* Washer, Frictional, Mat'l, 10 Ga, 7/16" id x 1-1/2" od		
800-MMMM 020201	Washer, Frictional, Mat'l, 12 Ga, 7/16" id x 1-3/4" od		
800-MMMM 030201	* Washer, Frictional, Mat'l, 10 Ga, 7/16" id x 1-3/4" od		
800-MMMM 020301	Washer, Frictional, Mat'l, 12 Ga, 7/16" id x 2-1/4" od		
800-MMMM 030301	* Washer, Frictional, Mat'l, 10 Ga, 7/16" id x 2-1/4" od		
800-MMMM 020102	Washer, Frictional, Mat'l, 12 Ga, 9/16" id x 1-1/2" od		
800-MMMM 030102	* Washer, Frictional, Mat'l, 10 Ga, 9/16" id x 1-1/2" od		
800-MMMM 021402	Washer, Frictional, Mat'l, 10 Ga, 9/16" id x 1-3/8" od		

**Available in C.S. only.
Commonly stocked in: C.S., Monel, Ty-304L, Ty-316L and Ty-410. Available in other materials and sizes upon request.*

ITEM NO.	ITEM DESCRIPTION	DOMED WASHERS	802
802-MMMM 101	Washer, Domed, Mat'l, 14 Ga, 7/16" id x 1-1/2" od		
802-MMMM 102	Washer, Domed, Mat'l, 14 Ga, 7/16" id x 1-3/4" od		
802-MMMM 302	*Washer, Domed, Mat'l, 10 Ga, 7/16" id x 1-3/4" od		
802-MMMM 111	Washer, Domed, Mat'l, 14 Ga, 9/16" id x 1-1/2" od		

**Available in C.S. only.
Commonly stocked in: Monel, Ty-304L, Ty-316L and Ty-410. Available in other materials upon request.*

ITEM NO.	ITEM DESCRIPTION	SPLIT LOCK WASHERS	803
803-MMMM 02	* Washer, Split Lock, Mat'l, 3/8"		
803-MMMM 03	**Washer, Split Lock, Mat'l, 1/2"		

**Commonly stocked in: C.S., Ty-304 and Ty-316.
**Commonly stocked in: Ty-304 and Ty-316.
Available in other materials and sizes upon request.*

ITEM NO.	ITEM DESCRIPTION	BOTTOM TRAY CLAMPS "Y"	902
902-MMMM 02	Clamp, Bottom Tray "Y", Mat'l, 1/2" Hole, 10 Ga		

Commonly stocked in: CS, Monel, Ty-304L, Ty-316L and Ty-410. Bottom Tray Clamp "Y" designed for use with 1" maximum thickness supports. Available in other materials upon request. For exotic material such as Titanium and Zirconium, please substitute the EM Clamp (#404) for the Y-Clamp. See Non-Standard section for the EM clamps.

STANDARD HARDWARE ITEMS

- ↳ 946-MMMM 201 MMMM
- ↳ Insert Material identification number from chart on p. 6.
- ↳ **Clamp, Bottom Tray "YN", w/ Nut, Mat'l, 10 Ga, 3/8"-16 UNC-2A Nut, Mat'l**
- ↳ Insert abbreviated Material name from p. 6.

ITEM NO.	ITEM DESCRIPTION	BOTTOM TRAY CLAMPS "YN"	946
----------	------------------	-------------------------	-----

946-MMMM 201 MMMM	Clamp, Bottom Tray "YN", w/ Nut, Mat'l, 10 Ga, 3/8"-16 UNC-2A Nut, Mat'l		
-------------------	--	--	--

Commonly stocked in: CS, Monel, Ty-304L, Ty-316L and Ty-410.
 Bottom Tray Clamp "YN" designed for use with 1" maximum thickness supports.
 Available in other materials upon request.

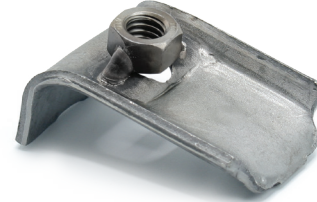

ITEM NO.	ITEM DESCRIPTION	BOTTOM TRAY CLAMPS "YB"	932
----------	------------------	-------------------------	-----

932-MMMM 021 MMMM	Clamp, Bottom Tray "YB", w/ bolt, Mat'l, 10 Ga, 3/8"-16 UNC-2A x 2" Bolt, Mat'l		
-------------------	---	--	--

Commonly stocked in: CS, Monel, Ty-304L, Ty-316L and Ty-410.
 Other material types and bolt lengths are available upon request.
 Bottom Tray Clamp "YB" designed for use with 1" maximum thickness supports.
 For exotic material such as Titanium and Zirconium, please substitute the EM Clamp (#406) for the YB-Clamp.
 See Non-Standard section for the EM clamps.



ITEM NO.	ITEM DESCRIPTION	BOTTOM TRAY CLAMPS #50	843
----------	------------------	------------------------	-----

843-MMMM 20	* Clamp, Bottom Tray #50, Mat'l, 12 Ga, 7/16" Hole		
843-MMMM 30	**Clamp, Bottom Tray #50, Mat'l, 10 Ga, 7/16" Hole		
843-MMMM 40	Clamp, Bottom Tray #50, Mat'l, 11 Ga, 7/16" Hole		

*Commonly stocked in CS, Monel, Ty-304L, Ty-316L and Ty-410.
 ** Available in C.S.
 Available in other materials upon request.
 Bottom Tray Clamp #50, 51, and 52 are designed for use with 3/4" maximum thickness supports.



ITEM NO.	ITEM DESCRIPTION	BOTTOM TRAY CLAMPS #51	844
----------	------------------	------------------------	-----

844-MMMM 21 MMMM	Clamp, Bottom Tray #51, Mat'l, 12 Ga, w/ nut 3/8"-16 UNC-2B, Mat'l		
844-MMMM 41 MMMM	Clamp, Bottom Tray #51, Mat'l, 11 Ga, w/ nut 3/8"-16 UNC-2B, Mat'l		
844-MMMM 31 MMMM	* Clamp, Bottom Tray #51, Mat'l, 10 Ga, w/ nut 3/8"-16 UNC-2B, Mat'l		

*Available in C.S.



ITEM NO.	ITEM DESCRIPTION	BOTTOM TRAY CLAMP #52	845
----------	------------------	-----------------------	-----

845-MMMM 21 MMMM	* Clamp, Bottom Tray #52, Mat'l, 12 Ga, w/ bolt 3/8"x 2" LG, Mat'l		
845-MMMM 22 MMMM	Clamp, Bottom Tray #52, Mat'l, 12 Ga, w/ bolt 3/8"x 2-1/2" LG, Mat'l		
845-MMMM 29 MMMM	Clamp, Bottom Tray #52, Mat'l, 12 Ga, w/ bolt 3/8"x 3" LG, Mat'l		
845-MMMM 41 MMMM	Clamp, Bottom Tray #52, Mat'l, 11 Ga, w/ bolt 3/8"x 2" LG, Mat'l		
845-MMMM 42 MMMM	Clamp, Bottom Tray #52, Mat'l, 11 Ga, w/ bolt 3/8"x 2-1/2" LG, Mat'l		
845-MMMM 49 MMMM	Clamp, Bottom Tray #52, Mat'l, 11 Ga, w/ bolt 3/8"x 3" LG, Mat'l		
845-MMMM 31 MMMM	**Clamp, Bottom Tray #52, Mat'l, 10 Ga, w/ bolt 3/8"x 2" LG, Mat'l		
845-MMMM 32 MMMM	**Clamp, Bottom Tray #52, Mat'l, 10 Ga, w/ bolt 3/8"x 2-1/2" LG, Mat'l		
845-MMMM 39 MMMM	**Clamp, Bottom Tray #52, Mat'l, 10 Ga, w/ bolt 3/8"x 3" LG, Mat'l		

*Commonly stocked in CS, Monel, Ty-304L, Ty-316L and Ty-410.
 ** Available in C.S.
 Available in other materials and bolt lengths upon request.
 Bottom Tray Clamp #50, 51, and 52 are designed for use with 3/4" maximum thickness supports.

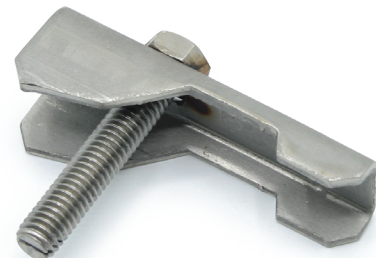

- **316-MMMM 0**
Insert Material identification number from chart on p. 6.
- **Clamp, Universal Lever #2, Mat'l, 14 Ga**
Insert abbreviated Material name from p. 6.

STANDARD HARDWARE ITEMS

ITEM NO.	ITEM DESCRIPTION	UNIVERSAL LEVER CLAMPS #2	316
316-MMMM 0	Clamp, Universal Lever #2, Mat'l, 14 Ga		
316-MMMM 1	* Clamp, Universal Lever #2, Mat'l, 12 Ga		

Commonly stocked in: Monel, Ty-304L, Ty-316L and Ty-410.
*Stocked in CS only.
Available in other materials upon request.

ITEM NO.	ITEM DESCRIPTION	TRAY CLAMPS	940
940-MMMM0101	Clamp, Tray, Mat'l, (for use w/ max support thickness of 5/8"), 12 Ga		

Commonly stocked in: Ty-304L, 316L and Ty-410.

ITEM NO.	ITEM DESCRIPTION	MANWAY LOCK CLAMPS #2 & 3	860
860-MMMM 4	Clamp, Manway Lock #3, Mat'l, 3/16"t		
860-MMMM 5	* Clamp, Manway Lock #2, Mat'l, 1/4"t		

Commonly stocked in: C.S., Monel, Ty-304L, 316L and Ty-410.
*Available in C.S.
Available in other materials upon request.

ITEM NO.	ITEM DESCRIPTION	MANWAY LOCK CLAMPS #20	861
861-MMMM 1	Clamp, Manway Lock #20, Mat'l, 3/16"t, for 3/8" Stud		
861-MMMM 3	* Clamp, Manway Lock #20, Mat'l, 1/4"t, for 3/8" Stud		

Commonly stocked in: C.S., Monel, Ty304L, 316L and Ty-410.
*Available in C.S.
Available in other materials upon request.

ITEM NO.	ITEM DESCRIPTION	BOTTOM TRAY CLAMPS "YD" (MANWAY)	903
903-MMMM 02	Clamp, Bottom Tray "YD", Hole for 3/8" "D" shape Manway Stud, Mat'l, 10 Ga		

Commonly stocked in: C.S., Monel, Ty-304L, Ty-316L and Ty-410.
Bottom Tray Clamp "YD" designed for use with 1" maximum thickness supports.
Available in other materials upon request.

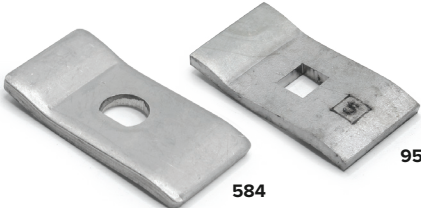
ITEM NO.	ITEM DESCRIPTION	MANWAY LOCK CLAMPS	584 951
584-MMMM 3	Clamp, Manway Lock, Mat'l, 10 Ga		
951-MMMM 3	Clamp, Manway Lock, Mat'l, 10 Ga		

Commonly stocked in: C.S., Ty-304L, Ty-316L and Ty-410.
Available in other materials upon request.
Manway Lock Clamp 584 has a "D" hole.
Manway Lock Clamp 951 has a SQ hole.

ITEM NO.	ITEM DESCRIPTION	MANWAY LOCK CLAMPS #45	863
863-MMMM 2	Clamp, Manway Lock #45, Mat'l, 12 Ga, for 3/8" Stud		

Commonly stocked in: Ty-304L, Ty-316L and Ty-410.
Available in other materials upon request.

STANDARD HARDWARE ITEMS

- ↳ 586-MMMM 3
Insert Material identification number from chart on p. 6.
- ↳ Clamp, Manway Lock #70, Mat'l, 10 Ga, for 1/2" Stud
Insert abbreviated Material name from p. 6.

ITEM NO.	ITEM DESCRIPTION	MANWAY LOCK CLAMP #70	586
----------	------------------	-----------------------	-----

586-MMMM 3	Clamp, Manway Lock #70, Mat'l, 10 Ga, for 1/2" Stud
------------	---

Commonly stocked in: Ty-304L, Ty-316L and Ty-410.
Available in other materials upon request.



ITEM NO.	ITEM DESCRIPTION	MANWAY POINTER #75	585
----------	------------------	--------------------	-----

585-MMMM 3	Pointer, Manway #75, Mat'l, 10 Ga, for 1/2" Stud
------------	--

Commonly stocked in: Ty-304L, Ty-316L and Ty-410.
Available in other materials upon request.



ITEM NO.	ITEM DESCRIPTION	MANWAY SEAL CLAMPS	583 952
----------	------------------	--------------------	-----------

583-MMMM 3	Clamp, Manway Seal, Mat'l, 10 Ga
952-MMMM 3	Clamp, Manway Seal, Mat'l, 10 Ga

Commonly stocked in: C.S., Ty-304L, Ty-316L and Ty-410.
Available in other materials upon request.
Manway Seal Clamp 583 has a "D" hole.
Manway Seal Clamp 952 has a SQ hole.



ITEM NO.	ITEM DESCRIPTION	MANWAY CLAMP	938
----------	------------------	--------------	-----

938-MMMM 01 MMMM	Clamp, Manway, Mat'l, 3/8"-16 UNC-2B Nut, Mat'l
------------------	---

Commonly stocked in: Ty-304L and Ty-410



ITEM NO.	ITEM DESCRIPTION	MANWAY LOCK STUDS ("D" Hole) #5, 7, & 10	865
----------	------------------	--	-----

865-MMMM 11	Stud, Manway Lock #5, Mat'l, 3/8"-16 UNC-2A x 2" LG
865-MMMM 12	Stud, Manway Lock #7, Mat'l, 3/8"-16 UNC-2A x 2-1/2" LG
865-MMMM 32	* Stud, Manway Lock #10, Mat'l, 1/2"-13 UNC-2A x 2-1/2" LG

*For use with Manway lock clamp #70 & Manway pointer #75 (Replaced MWL Stud #9, Part No. 587)
Commonly stocked in: C.S., Monel, Ty-304L, Ty-316L and Ty-410.
Available in other materials upon request.



ITEM NO.	ITEM DESCRIPTION	MANWAY LOCK STUDS (SQ HOLE)	950
----------	------------------	-----------------------------	-----

950-MMMM11	Stud, Manway Lock SQ, Mat'l, 3/8"-16 UNC-2A x 2" LG
950-MMMM12	Stud, Manway Lock SQ, Mat'l, 3/8"-16 UNC-2A x 2-1/2" LG

Commonly stocked in: CS, Monel, Ty-304L, Ty-316L and Ty-410.
Available in other materials upon request.

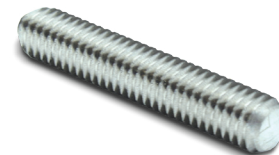

ITEM NO.	ITEM DESCRIPTION	TEE BOLTS (MANWAY)	300
----------	------------------	--------------------	-----

300-MMMM 2	* Tee Bolt (Manway), Mat'l, 1/2"-13 UNC-2A
------------	--

*Commonly stocked in Monel, Ty 304L, Ty-316L and Ty-410.
Available in other materials upon request.



- 909-MMMM 001
- Insert Material identification number from chart on p. 6.
- Seal Plate #10, Mat'l, 14 Ga, 3" LG
- Insert abbreviated Material name from p. 6.

STANDARD HARDWARE ITEMS

ITEM NO.	ITEM DESCRIPTION	SEAL PLATES	909
909-MMMM 001	Seal Plate #10, Mat'l, 14 Ga, 3" LG		909 Replaced Item #848
909-MMMM 002	Seal Plate #10A, Mat'l, 14 Ga, 3-1/2" LG		
909-MMMM 003	Seal Plate #10B, Mat'l, 14 Ga, 4" LG		
909-MMMM 004	Seal Plate #10C, Mat'l, 14 Ga, 4-1/2" LG		
909-MMMM 005	Seal Plate #10D, Mat'l, 14 Ga, 5" LG		
909-MMMM 000	Seal Plate #10X2, Mat'l, 14 Ga, 2" LG		
909-MMMM 006	Seal Plate, Mat'l, 14 Ga, 2-1/2" LG		
909-MMMM 007	Seal Plate, Mat'l, 14 Ga, 6" LG		
909-MMMM 008	Seal Plate, Mat'l, 14 Ga, 5-1/2" LG		

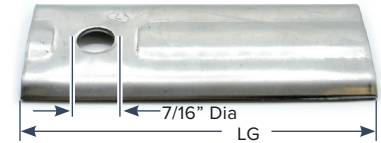

Seal plates supplied in C.S. are 10 Ga. The last three digits of the item No. are different. For example, 201 instead of 001 for Seal plate #10, 202 instead of 002 for Seal plate #10A.

Commonly stocked in: C.S., Monel, Ty-304L, Ty-316L and Ty-410. Available in other materials upon request.

ITEM NO.	ITEM DESCRIPTION	SEAL PLATE	936
936-MMMM 01	Seal Plate, Mat'l, 16 Ga		

Commonly stocked in: Ty-304L, Ty-316L and Ty-410.



ITEM NO.	ITEM DESCRIPTION	BEAM PLATE	935
935-MMMM 01	Beam Plate, Mat'l, 14 Ga		

Commonly stocked in: Ty-304L and Ty-410.

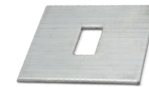

ITEM NO.	ITEM DESCRIPTION	FRICTION PLATE	937
937-MMMM 01	Friction Plate, Mat'l, 12 Ga		

Commonly stocked in: Ty-304L and Ty-410.



ITEM NO.	ITEM DESCRIPTION	BOTTOM CLAMPS #5	841
841-MMMM 20	Clamp, Bottom #5, Mat'l, 12 Ga, 7/16" Hole		

Commonly stocked in: Ty-304L, Ty-316L and Ty-410.
Available in other materials upon request.



ITEM NO.	ITEM DESCRIPTION	CLIP ANGLES #8 & 10	826
826-MMMM 11	* Clip Angle # 8, Mat'l, 14 Ga		
826-MMMM 31	** Clip Angle #10, Mat'l, 10 Ga		

Commonly stocked in: * 14 Ga: Monel, Ty-304L, Ty-316L and Ty-410.
** 10 Ga: C.S.
Available in other materials upon request.



ITEM NO.	ITEM DESCRIPTION	SINGLE BAR CLAMPS	321
321-MMMM 01	**Clamp, Single Bar, Mat'l, 10 Ga, 7/16" Hole		
321-MMMM 02	**Clamp, Single Bar, Mat'l, 10 Ga, 9/16" Hole		
321-MMMM 11	* Clamp, Single Bar, Mat'l, 14 Ga, 7/16" Hole		

*Commonly stocked in: Monel, Ty-304L, Ty-316L and Ty-410.
**Commonly stocked in: C.S.
Available in other materials upon request.



ITEM NO.	ITEM DESCRIPTION	WEDGE #2	821
821-MMMM	Wedge #2, Mat'l, 16 Ga		

Commonly stocked in: Ty-304L, Ty-316L and Ty-410.
Available in other materials upon request.



ITEM NO.	ITEM DESCRIPTION	WEDGE	939
939-MMMM 01	Wedge, Mat'l, 16 Ga		

Commonly stocked in: Ty-304L and Ty-410.



STANDARD HARDWARE ITEMS

- ↳ 700-MMMM 110
Insert Material identification number from chart on p. 6.
- ↳ * Gasket, Washer, Mat'l, 1/16"t x 3/8" id x 1" od
Insert abbreviated Material name from p. 6.

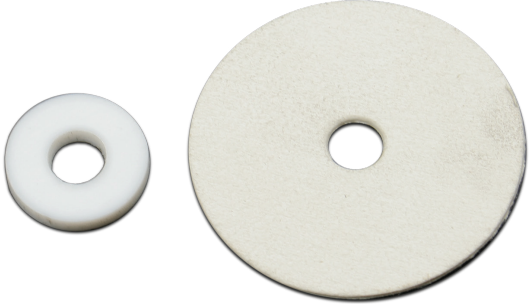
ITEM NO.	ITEM DESCRIPTION	WASHER GASKETS	700
700-MMMM 110	* Gasket, Washer, Mat'l, 1/16"t x 3/8" id x 1" od		
700-MMMM 120	* Gasket, Washer, Mat'l, 1/16"t x 3/8" id x 1-1/2" od		
700-MMMM 130	* Gasket, Washer, Mat'l, 1/16"t x 3/8" id x 1-3/4" od		
700-MMMM 140	Gasket, Washer, Mat'l, 1/16"t x 3/8" id x 2-1/4" od		
700-MMMM 150	Gasket, Washer, Mat'l, 1/16"t x 3/8" id x 1-1/4" od		
700-MMMM 210	Gasket, Washer, Mat'l, 1/8"t x 3/8" id x 1" od		
700-MMMM 220	Gasket, Washer, Mat'l, 1/8"t x 3/8" id x 1-1/2" od		
700-MMMM 230	Gasket, Washer, Mat'l, 1/8"t x 3/8" id x 1-3/4" od		
700-MMMM 240	Gasket, Washer, Mat'l, 1/8"t x 3/8" id x 2-1/4" od		
700-MMMM 250	Gasket, Washer, Mat'l, 1/8"t x 3/8" id x 1-1/4" od		

*Commonly stocked in: D-8080.
Material Identification No: (775G) D-8080, (760G) Teflon, (797G) Neoprene, (780G) TN-9000.

ITEM NO.	ITEM DESCRIPTION	TAPE GASKETING	GKT
GKT-MMMM 0160251-I	* Gasket, Tape, Mat'l, 1/16"t x 1"w		
GKT-MMMM 0160320-I	* Gasket, Tape, Mat'l, 1/16"t x 1-1/4"w		
GKT-MMMM 0160380-I	* Gasket, Tape, Mat'l, 1/16"t x 1-1/2"w		
GKT-MMMM 0160510-I	* Gasket, Tape, Mat'l, 1/16"t x 2"w		
GKT-MMMM 0160640-I	* Gasket, Tape, Mat'l, 1/16"t x 2-1/2"w		
GKT-MMMM 0160760-I	* Gasket, Tape, Mat'l, 1/16"t x 3"w		
GKT-MMMM0320251-I	Gasket, Tape, Mat'l, 1/8"t x 1"w		
GKT-MMMM0320320-I	Gasket, Tape, Mat'l, 1/8"t x 1-1/4"w		
GKT-MMMM0320380-I	Gasket, Tape, Mat'l, 1/8"t x 1-1/2"w		
GKT-MMMM0320510-I	Gasket, Tape, Mat'l, 1/8"t x 2"w		

*Commonly stocked in: Fiberglass
Material Identification No: (770G) Fiberglass, (760G) Teflon, (797G) Neoprene and (750G) Ceramic Fiber.
Note: All types except 1" wide are available in both Drop Warp (DW) and Non-Drop Warp (NDW) styles.

ITEM NO.	ITEM DESCRIPTION	GASKET ROPES (SQUARE & ROUND)	GKR
GKR-MMMM 20950-I	Rope, Gasket, Square, Mat'l, 3/8" x 3/8"		
GKR-MMMM 21270-I	Rope, Gasket, Square, Mat'l, 1/2" x 1/2"		
GKR-MMMM 21590-I	Rope, Gasket, Square, Mat'l, 5/8" x 5/8"		
GKR-MMMM 21910-I	Rope, Gasket, Square, Mat'l, 3/4" x 3/4"		
GKR-MMMM 22540-I	Rope, Gasket, Square, Mat'l, 1" x 1"		
GKR-MMMM 10320-I	Rope, Gasket, Round, Mat'l, 1/8"		
GKR-MMMM 10640-I	Rope, Gasket, Round, Mat'l, 1/4"		
GKR-MMMM 10950-I	* Rope, Gasket, Round, Mat'l, 3/8"		
GKR-MMMM 11270-I	* Rope, Gasket, Round, Mat'l, 1/2"		
GKR-MMMM 11590-I	Rope, Gasket, Round, Mat'l, 5/8"		
GKR-MMMM 11910-I	Rope, Gasket, Round, Mat'l, 3/4"		
GKR-MMMM 12540-I	Rope, Gasket, Round, Mat'l, 1"		

*Commonly stocked in Fiberglass.
Material Identification No: (770G) Fiberglass, (760G) Teflon, (797G) Neoprene, (750G) Ceramic Fiber and (798G) Gortex.
Specify Last # "0"= Standard, "1" = Braided (Ex. GKR-MMMM 10950-I = Standard, GKR-MMMM 10951-I = Braided)

- 307-MMMM 121
- Insert Material identification number from chart on p. 6.
- Cap, Flexitray Type "AC-U", Mat'l, 12 Ga (2.5mm), 7/16" (11.11mm) leg length
- Insert abbreviated Material name from p. 6.

STANDARD HARDWARE ITEMS

ITEM NO.	ITEM DESCRIPTION	FLEXITRAY® CAP TYPES AC-U - AE-U - AB-U	307
307-MMMM 121	Cap, Flexitray Type "AC-U", Mat'l, 12 Ga (2.5mm), 7/16" (11.11mm) leg length		
307-MMMM 122	Cap, Flexitray Type "AD-U", Mat'l, 12 Ga (2.5mm), 1/2" (12.7mm) leg length		
307-MMMM 123	Cap, Flexitray Type "AE-U", Mat'l, 12 Ga (2.5mm), 9/16" (14.29mm) leg length		
307-MMMM 141	* Cap, Flexitray Type "AC-U", Mat'l, 14 Ga (2mm), 7/16" (11.11mm) leg length		
307-MMMM 142	Cap, Flexitray Type "AD-U", Mat'l, 14 Ga (2mm), 1/2" (12.7mm) leg length		
307-MMMM 143	* Cap, Flexitray Type "AE-U", Mat'l, 14 Ga (2mm), 9/16" (14.29mm) leg length		
307-MMMM 161	* Cap, Flexitray Type "AC-U", Mat'l, 16 Ga (1.5mm), 7/16" (11.11mm) leg length		
307-MMMM 162	Cap, Flexitray Type "AD-U", Mat'l, 16 Ga (1.5mm), 1/2" (12.7mm) leg length		
307-MMMM 163	* Cap, Flexitray Type "AE-U", Mat'l, 16 Ga (1.5mm), 9/16" (14.29mm) leg length		
307-MMMM 181	Cap, Flexitray Type "AC-U", Mat'l, 18 Ga (1.2mm), 7/16" (11.11mm) leg length		
307-MMMM 182	Cap, Flexitray Type "AD-U", Mat'l, 18 Ga (1.2mm), 1/2" (12.7mm) leg length		
307-MMMM 183	Cap, Flexitray Type "AE-U", Mat'l, 18 Ga (1.2mm), 9/16" (14.29mm) leg length		
307-MMMM 120	Cap, Flexitray Type "AB-U", Mat'l, 12 Ga (2.5mm), 3/8" (9.53mm) leg length		
307-MMMM 140	* Cap, Flexitray Type "AB-U", Mat'l, 14 Ga (2mm), 3/8" (9.53mm) leg length		
307-MMMM 160	* Cap, Flexitray Type "AB-U", Mat'l, 16 Ga (1.5mm), 3/8" (9.53mm) leg length		
307-MMMM 180	Cap, Flexitray Type "AB-U", Mat'l, 18 Ga (1.2mm), 3/8" (9.53mm) leg length		



*Commonly stocked in: Ty-304L, Ty-316L and Ty-410.
Available in other materials upon request.

ITEM NO.	ITEM DESCRIPTION	FLEXITRAY® CAP TYPES AC-Z - AE-Z - AB-Z	308
308-MMMM 121	Cap, Flexitray Type "AC-Z" (Flush Seat), Mat'l, 12 Ga (2.5mm), 7/16"(11.11mm) leg length		
308-MMMM 122	Cap, Flexitray Type "AD-Z" (Flush Seat), Mat'l, 12 Ga (2.5mm), 1/2" (12.7mm) leg length		
308-MMMM 123	Cap, Flexitray Type "AE-Z" (Flush Seat), Mat'l, 12 Ga (2.5mm), 9/16" (14.29mm) leg length		
308-MMMM 141	* Cap, Flexitray Type "AC-Z" (Flush Seat), Mat'l, 14 Ga (2mm), 7/16" (11.11mm) leg length		
308-MMMM 142	Cap, Flexitray Type "AD-Z" (Flush Seat), Mat'l, 14 Ga (2mm), 1/2" (12.7mm) leg length		
308-MMMM 143	Cap, Flexitray Type "AE-Z" (Flush Seat), Mat'l, 14 Ga (2mm), 9/16" (14.29mm) leg length		
308-MMMM 161	* Cap, Flexitray Type "AC-Z" (Flush Seat), Mat'l, 16 Ga (1.5mm), 7/16" (11.11mm) leg length		
308-MMMM 162	Cap, Flexitray Type "AD-Z" (Flush Seat), Mat'l, 16 Ga (1.5mm), 1/2"(12.7mm) leg length		
308-MMMM 163	Cap, Flexitray Type "AE-Z" (Flush Seat), Mat'l, 16 Ga (1.5mm), 9/16"(14.29mm) leg length		
308-MMMM 181	Cap, Flexitray Type "AC-Z" (Flush Seat), Mat'l, 18 Ga (1.2mm), 7/16"(11.11mm) leg length		
308-MMMM 182	Cap, Flexitray Type "AD-Z" (Flush Seat), Mat'l, 18 Ga (1.2mm), 1/2"(12.7mm) leg length		
308-MMMM 183	Cap, Flexitray Type "AE-Z" (Flush Seat), Mat'l, 18 Ga (1.2mm), 9/16" (14.29mm) leg length		
308-MMMM 120	Cap, Flexitray Type "AB-Z" (Flush Seat), Mat'l, 12 Ga (2.5mm), 3/8" (9.53mm) leg length		
308-MMMM 140	* Cap, Flexitray Type "AB-Z" (Flush Seat), Mat'l, 14 Ga (2mm), 3/8" (9.53mm) leg length		
308-MMMM 160	* Cap, Flexitray Type "AB-Z" (Flush Seat), Mat'l, 16 Ga (1.5mm), 3/8" (9.53mm) leg length		
308-MMMM 180	Cap, Flexitray Type "AB-Z" (Flush Seat), Mat'l, 18 Ga (1.2mm), 3/8" (9.53mm) leg length		



*Commonly stocked in: Ty-304L, Ty-316L and Ty-410.
Available in other materials upon request.

STANDARD HARDWARE ITEMS

- 303-MMMM 11
Insert Material identification number from chart on p. 6.
- Cap, Flexitray Type "U", Mat'l, 11 Ga (3mm)
Insert abbreviated Material name from p. 6.

ITEM NO.	ITEM DESCRIPTION	FLEXITRAY® CAPS TYPE U FLEXITRAY® CAPS HOLDDOWN TYPE M	303 311
303-MMMM 11	Cap, Flexitray Type "U", Mat'l, 11 Ga (3mm)		
303-MMMM 12	Cap, Flexitray Type "U", Mat'l, 12 Ga (2.5mm)		
303-MMMM 14	* Cap, Flexitray Type "U", Mat'l, 14 Ga (2mm)		
303-MMMM 16	* Cap, Flexitray Type "U", Mat'l, 16 Ga (1.5mm)		
303-MMMM 18	Cap, Flexitray Type "U", Mat'l, 18 Ga (1.2mm)		
311-MMMM 11	Cap Holddown, Flexitray Type "M", Mat'l, 11 Ga (3mm)		
311-MMMM 12	Cap Holddown, Flexitray Type "M", Mat'l, 12 Ga (2.5mm)		
311-MMMM 12	**Cap Holddown, Flexitray Type "M", Mat'l, 14 Ga (2mm)		

* Commonly stocked in: Monel, Ty-304L, Ty-316L and Ty-410. Available in other materials upon request.
 ** Commonly Stocked in Monel.

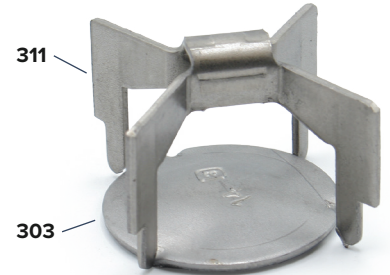

ITEM NO.	ITEM DESCRIPTION	FLEXITRAY® CAPS TYPE Z FLEXITRAY® CAPS HOLDDOWN TYPE MQ	304 313
304-MMMM 11	Cap, Flexitray Type "Z", Mat'l, 11 Ga (3mm)		
304-MMMM 12	Cap, Flexitray Type "Z", Mat'l, 12 Ga (2.5mm)		
304-MMMM 14	* Cap, Flexitray Type "Z", Mat'l, 14 Ga (2mm)		
304-MMMM 16	* Cap, Flexitray Type "Z", Mat'l, 16 Ga (1.5mm)		
304-MMMM 18	Cap, Flexitray Type "Z", Mat'l, 18 Ga (1.2mm)		
313-MMMM 11	Cap Holddown, Flexitray Type "M", Mat'l, 11 Ga (3mm)		
313-MMMM 12	Cap Holddown, Flexitray Type "M", Mat'l, 12 Ga (2.5mm)		
313-MMMM 14	Cap Holddown, Flexitray Type "M", Mat'l, 14 Ga (2mm)		

* Commonly Stocked in Monel, Ty-304L, Ty-316L and Ty-410. Available in other materials upon request.



ITEM NO.	ITEM DESCRIPTION	FLEXITRAY® CAPS TYPE NRU & NRZ FLEXITRAY® CAPS HOLDDOWN TYPE Q & R	305 310
305-MMMM 121	Cap, Flexitray Type "NRU", Mat'l, 12 Ga (2.5mm), 1		
305-MMMM 141	Cap, Flexitray Type "NRU", Mat'l, 14 Ga (2mm), 1		
305-MMMM 161	Cap, Flexitray Type "NRU", Mat'l, 16 Ga (1.5mm), 1		
305-MMMM 122	Cap, Flexitray Type "NRZ" (Flush Seat), Mat'l, 12 Ga (2.5mm), 2		
305-MMMM 142	Cap, Flexitray Type "NRZ" (Flush Seat), Mat'l, 14 Ga (2mm), 2		
305-MMMM 162	Cap, Flexitray Type "NRZ" (Flush Seat), Mat'l, 16 Ga (1.5mm), 2		
310-MMMM 012	* Cap Holddown, Flexitray Type "Q", Mat'l, 12 Ga (2.5mm)		
310-MMMM 014	** Cap Holddown, Flexitray Type "Q", Mat'l, 14 Ga (2mm)		
310-MMMM 112	Cap Holddown, Flexitray Type "R", Mat'l, 12 Ga (2.5mm)		
310-MMMM 114	***Cap Holddown, Flexitray Type "R", Mat'l, 14 Ga (2mm)		

* Commonly stocked in CS. ***Commonly stocked in Ty 304L and Ty-410.
 ** Commonly stocked in Ty-304L, Ty-316L and Ty-410. Available in other materials upon request.



ITEM NO.	ITEM DESCRIPTION	PROVALVE® TYPE FV-2 & FV-3	467
467-MMMM 1020	Provalve Type "FV-2", Mat'l, 10 Ga (3.5mm), 1/2" (13mm) Lift, 1/4" (7mm) Tab Width		
467-MMMM 1120	Provalve Type "FV-2", Mat'l, 11 Ga (3mm), 1/2" (13mm) Lift, 1/4" (7mm) Tab Width		
467-MMMM 1220	Provalve Type "FV-2", Mat'l, 12 Ga (2.5mm), 1/2" (13mm) Lift, 1/4" (7mm) Tab Width		
467-MMMM 1420	* Provalve Type "FV-2", Mat'l, 14 Ga (2mm), 1/2" (13mm) Lift, 1/4" (7mm) Tab Width		
467-MMMM 1620	* Provalve Type "FV-2", Mat'l, 16 Ga (1.5mm), 1/2" (13mm) Lift, 1/4" (7mm) Tab Width		
467-MMMM 1820	Provalve Type "FV-2", Mat'l, 18 Ga (1.2mm), 1/2" (13mm) Lift, 1/4" (7mm) Tab Width		
467-MMMM 1030	Provalve Type "FV-3", Mat'l, 10 Ga (3.5mm), 11/16" (17mm) Lift, 1/4" (7mm) Tab Width		
467-MMMM 1130	Provalve Type "FV-3", Mat'l, 11 Ga (3mm), 11/16" (17mm) Lift, 1/4" (7mm) Tab Width		
467-MMMM 1230	Provalve Type "FV-3", Mat'l, 12 Ga (2.5mm), 11/16" (17mm) Lift, 1/4" (7mm) Tab Width		
467-MMMM 1430	* Provalve Type "FV-3", Mat'l, 14 Ga (2mm), 11/16" (17mm) Lift, 1/4" (7mm) Tab Width		
467-MMMM 1630	* Provalve Type "FV-3", Mat'l, 16 Ga (1.5mm), 11/16" (17mm) Lift, 1/4" (7mm) Tab Width		
467-MMMM 1830	Provalve Type "FV-3", Mat'l, 18 Ga (1.2mm), 11/16" (17mm) Lift, 1/4" (7mm) Tab Width		

* Commonly stocked in: Ty-304L, Ty-316L and Ty-410. Provalves Type "FV-3" are available with slot.
 Note: Provalves are available with 3/8" (10mm) tab width. Available in other materials upon request.



- **934-MMMM 01**
Insert Material identification number from chart on p. 6.
- **Ballast (Valve SI) Unit, Mat'l, 16 Ga (1.5mm)**
Insert abbreviated Material name from p. 6.

STANDARD HARDWARE ITEMS

ITEM NO.	ITEM DESCRIPTION	BALLAST (VALVE SI) UNITS	934
934-MMMM 01	Ballast (Valve SI) Unit, Mat'l, 16 Ga (1.5mm)		
934-MMMM 02	Ballast (Valve SI) Unit, Mat'l, 14 Ga (2mm)		

Commonly stocked in: Ty-304L and Ty-410.



ITEM NO.	ITEM DESCRIPTION	MINI VALVES TYPES MV-1	620
620-MMMM 7518	Mini-Valve MV-1, Mat'l, 0.3375" (8.57mm) leg length, 18 Ga (1.2mm)		
620-MMMM 7516	Mini-Valve MV-1, Mat'l, 0.3375" (8.57mm) leg length, 16 Ga (1.5mm)		
620-MMMM 7514	Mini-Valve MV-1, Mat'l, 0.3375" (8.57mm) leg length, 14 Ga (2mm)		
620-MMMM 6518	* Mini-Valve MV-1, Mat'l, 0.3375" (8.57mm) leg length, 18 Ga (1.2mm)		
620-MMMM 6516	* Mini-Valve MV-1, Mat'l, 0.3375" (8.57mm) leg length, 16 Ga (1.5mm)		
620-MMMM 6514	* Mini-Valve MV-1, Mat'l, 0.3375" (8.57mm) leg length, 14 Ga (2mm)		
620-MMMM 7618	Mini-Valve MV-1, Mat'l, 0.3925" (9.97mm) leg length, 18 Ga (1.2mm)		
620-MMMM 7616	Mini-Valve MV-1, Mat'l, 0.3925" (9.97mm) leg length, 16 Ga (1.5mm)		
620-MMMM 7614	Mini-Valve MV-1, Mat'l, 0.3925" (9.97mm) leg length, 14 Ga (2mm)		
620-MMMM 6618	* Mini-Valve MV-1, Mat'l, 0.3925" (9.97mm) leg length, 18 Ga (1.2mm)		
620-MMMM 6616	* Mini-Valve MV-1, Mat'l, 0.3925" (9.97mm) leg length, 16 Ga (1.5mm)		
620-MMMM 6614	* Mini-Valve MV-1, Mat'l, 0.3925" (9.97mm) leg length, 14 Ga (2mm)		

*Flush Seat.



ITEM NO.	ITEM DESCRIPTION	MINI VALVES TYPE MV-9	622
622-MMMM 9518	Mini-Valve MV-9, Mat'l, 5/16" (7.94mm) leg length, 18 Ga (1.2mm)		
622-MMMM 5518	* Mini-Valve MV-9, Mat'l, 5/16" (7.94mm) leg length, 18 Ga (1.2mm)		
622-MMMM 9318	Mini-Valve MV-9, Mat'l, 3/16" (4.76mm) leg length, 18 Ga (1.2mm)		
622-MMMM 5318	* Mini-Valve MV-9, Mat'l, 3/16" (4.76mm) leg length, 18 Ga (1.2mm)		
622-MMMM 9516	Mini-Valve MV-9, Mat'l, 5/16" (7.94mm) leg length, 16 Ga (1.5mm)		
622-MMMM 5516	* Mini-Valve MV-9, Mat'l, 5/16" (7.94mm) leg length, 16 Ga (1.5mm)		

*Flush Seat.



ITEM NO.	ITEM DESCRIPTION	MINI VALVE TYPE VG-9	621
621-MMMM 8516	Mini-Valve VG-9, Mat'l, 16 Ga (1.5mm)		



STANDARD HARDWARE ITEMS

- ↳ 630-MMMM 1614
Insert Material identification number from chart on p. 6.
- ↳ * Rectangular Valve Unit , Mat'l, 3/8" leg length, 14 Ga (2mm)
Insert abbreviated Material name from p. 6.

ITEM NO.	ITEM DESCRIPTION	RECTANGULAR VALVE UNITS	630 631
630-MMMM 1614	* Rectangular Valve Unit , Mat'l, 3/8" leg length, 14 Ga (2mm)		
630-MMMM 1616	* Rectangular Valve Unit , Mat'l, 3/8" leg length, 16 Ga (1.5mm)		
630-MMMM 1618	* Rectangular Valve Unit , Mat'l, 3/8" leg length, 18 Ga (1.2mm)		
630-MMMM 1714	* Rectangular Valve Unit , Mat'l, 7/16" leg length, 14 Ga (2mm)		
630-MMMM 1716	* Rectangular Valve Unit , Mat'l, 7/16" leg length, 16 Ga (1.5mm)		
630-MMMM 1718	* Rectangular Valve Unit , Mat'l, 7/16" leg length, 18 Ga (1.2mm)		
630-MMMM 1814	Rectangular Valve Unit , Mat'l, 1/2" leg length, 14 Ga (2mm)		
630-MMMM 1816	Rectangular Valve Unit , Mat'l, 1/2" leg length, 16 Ga (1.5mm)		
630-MMMM 1818	Rectangular Valve Unit , Mat'l, 1/2" leg length, 18 Ga (1.2mm)		
631-MMMM 1614	* Half-Rectangular Valve Unit , Mat'l, 3/8" leg length, 14 Ga (2mm)		
631-MMMM 1616	* Half-Rectangular Valve Unit , Mat'l, 3/8" leg length, 16 Ga (1.5mm)		
631-MMMM 1618	* Half-Rectangular Valve Unit , Mat'l, 3/8" leg length, 18 Ga (1.2mm)		
631-MMMM 1714	* Half-Rectangular Valve Unit , Mat'l, 7/16" leg length, 14 Ga (2mm)		
631-MMMM 1716	* Half-Rectangular Valve Unit , Mat'l, 7/16" leg length, 16 Ga (1.5mm)		
631-MMMM 1718	* Half-Rectangular Valve Unit , Mat'l, 7/16" leg length, 18 Ga (1.2mm)		
631-MMMM 1814	Half-Rectangular Valve Unit , Mat'l, 1/2" leg length, 14 Ga (2mm)		
631-MMMM 1816	Half-Rectangular Valve Unit , Mat'l, 1/2" leg length, 16 Ga (1.5mm)		
631-MMMM 1818	Half-Rectangular Valve Unit , Mat'l, 1/2" leg length, 18 Ga (1.2mm)		

*Commonly stocked in Ty-304L, Ty-316L and Ty-410.
Available in other materials upon request.

ITEM NO.	ITEM DESCRIPTION	CAPS FTC, FTD & FTE UNITS	397
397-MMMM 0116	Cap FTC, Mat'l, 16 Ga (1.5mm), 0.47" (12mm) leg length		
397-MMMM 0216	Cap FTD, Mat'l, 16 Ga (1.5mm), 0.53" (13.5mm) leg length		
397-MMMM 0316	Cap FTE, Mat'l, 16 Ga (1.5mm), 0.59" (15mm) leg length		
397-MMMM 0114	Cap FTC, Mat'l, 14 Ga (2mm), 0.47" (12mm) leg length		
397-MMMM 0214	Cap FTD, Mat'l, 14 Ga (2mm), 0.53" (13.5mm) leg length		
397-MMMM 0314	Cap FTE, Mat'l, 14 Ga (2mm), 0.59" (15mm) leg length		

NON-STANDARD HARDWARE ITEMS

- **892-MMMM 01**
Insert Material identification number from chart on p. 6.
- **Nut, Heavy Hex. Mat'l, 3/8"-16 UNC-2B**
Insert abbreviated Material name from p. 6.

ITEM NO.	ITEM DESCRIPTION	HEAVY HEX NUTS	892
892-MMMM 01	Nut, Heavy Hex. Mat'l, 3/8"-16 UNC-2B		
892-MMMM 02	Nut, Heavy Hex. Mat'l, 1/2"-13 UNC-2B		

Available in other diameters.



ITEM NO.	ITEM DESCRIPTION	HEAVY HEX HEAD BOLTS	885
885-MMMM 1204	Bolt, Heavy Hex. Head Mat'l, 3/8"-16 UNC-2A x 1" LG		
885-MMMM 1208	Bolt, Heavy Hex. Head, Mat'l, 3/8"-16 UNC-2A x 2" LG		
885-MMMM 0108	Bolt, Heavy Hex. Head, Mat'l, 1/2"-13 UNC-2A x 2" LG		
885-MMMM 0112	Bolt, Heavy Hex. Head, Mat'l, 1/2"-13 UNC-2A x 3" LG		

Available in other diameters and lengths.



ITEM NO.	ITEM DESCRIPTION	CARRIAGE BOLTS	881
881-MMMM 0210	Bolt, Carriage, Mat'l, 3/8"-16 UNC-2A*		

* Represents the length of Bolt in 1/4" increments (10 x 1/4" = 2-1/2")
Available in other diameters and lengths.



ITEM NO.	ITEM DESCRIPTION	ECCENTRIC WASHERS	804
804-MMMM 1	Washer, Eccentric (1-1/2" od), Mat'l, 14 Ga		
804-MMMM 2	Washer, Eccentric (1-1/2" od), Mat'l, 12 Ga		
804-MMMM 3	Washer, Eccentric (1-1/2" od), Mat'l, 10 Ga		
804-MMMM 4	Washer, Eccentric (1-1/2" od), Mat'l, 3/16"t		
804-MMMM 5	Washer, Eccentric (1-1/2" od), Mat'l, 1/4"t		
804-MMMM 6	Washer, Eccentric (1-1/2" od), Mat'l, 11 Ga		



NON-STANDARD HARDWARE ITEMS

- ↳ **837-MMMM 235**
Insert Material identification number from chart on p. 6.
- ↳ **Clamp, Bottom Tray #53, Mat'l, 12 Ga, Tab length**
Insert abbreviated Material name from p. 6.

ITEM NO.	ITEM DESCRIPTION	BOTTOM TRAY CLAMPS #53	837
837-MMMM 235	Clamp, Bottom Tray #53, Mat'l, 12 Ga, Tab length		
837-MMMM 435	Clamp, Bottom Tray #53, Mat'l, 11 Ga, Tab length		
837-MMMM 335	*Clamp, Bottom Tray #53, Mat'l, 10 Ga, Tab length		

*Available in C.S.



ITEM NO.	ITEM DESCRIPTION	BOTTOM TRAY CLAMPS #54	838
838-MMMM 21 MMMM	Clamp, Bottom Tray #54, Mat'l, 12 Ga, w/ nut, 3/8"-16 UNC-2B, Mat'l		
838-MMMM 31 MMMM	*Clamp, Bottom Tray #54, Mat'l, 10 Ga, w/ nut, 3/8"-16 UNC-2B, Mat'l		
838-MMMM 41 MMMM	Clamp, Bottom Tray #54, Mat'l, 11 Ga, w/ nut, 3/8"-16 UNC-2B, Mat'l		

*Available in C.S.



ITEM NO.	ITEM DESCRIPTION	BOTTOM TRAY CLAMP #55	847
847-MMMM 21 MMMM	Clamp, Bottom Tray #55, Mat'l, 12 Ga, w/ bolt 3/8"x 2" LG, Mat'l		
847-MMMM 22 MMMM	Clamp, Bottom Tray #55, Mat'l, 12 Ga, w/ bolt 3/8"x 2-1/2" LG, Mat'l		
847-MMMM 29 MMMM	Clamp, Bottom Tray #55, Mat'l, 12 Ga, w/ bolt 3/8"x 3" LG, Mat'l		
847-MMMM 41 MMMM	Clamp, Bottom Tray #55, Mat'l, 11 Ga, w/ bolt 3/8"x 2" LG, Mat'l		
847-MMMM 42 MMMM	Clamp, Bottom Tray #55, Mat'l, 11 Ga, w/ bolt 3/8"x 2-1/2" LG, Mat'l		
847-MMMM 49 MMMM	Clamp, Bottom Tray #55, Mat'l, 11 Ga, w/ bolt 3/8"x 3" LG, Mat'l		
847-MMMM 31 MMMM	*Clamp, Bottom Tray #55, Mat'l, 10 Ga, w/ bolt 3/8"x 2" LG, Mat'l		
847-MMMM 32 MMMM	*Clamp, Bottom Tray #55, Mat'l, 10 Ga, w/ bolt 3/8"x 2-1/2" LG, Mat'l		
847-MMMM 39 MMMM	*Clamp, Bottom Tray #55, Mat'l, 10 Ga, w/ bolt 3/8"x 3" LG, Mat'l		

*Available in C.S.

Bottom Tray Clamp #53, 54 and 55 are designed for use with supports thicker than 3/4".



- **822-MMMM 30**
- Insert Material identification number from chart on p. 6.
- **Clamp, Bottom Tray #50SWN, Mat'l, 10 Ga, 7/16" Hole**
- Insert abbreviated Material name from p. 6.

NON-STANDARD HARDWARE ITEMS

ITEM NO.	ITEM DESCRIPTION	BOTTOM TRAY CLAMP 50SWN	822
822-MMMM 30	Clamp, Bottom Tray #50SWN, Mat'l, 10 Ga, 7/16" Hole		
822-MMMM 31	Clamp, Bottom Tray #50SWN, Mat'l, 10 Ga, 9/16" Hole		
822-MMMM 301 MMMM	Clamp, Bottom Tray #50SWN, Mat'l, 10 Ga, 7/16" Hole w/ 3/8" welded nut, Mat'l		

Replaces the old Bottom Tray Clamps #10 & 12 Series.

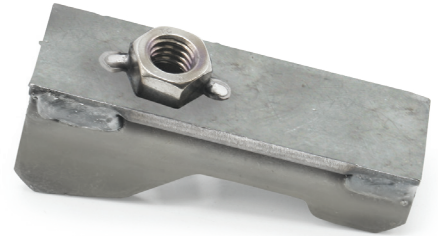

ITEM NO.	ITEM DESCRIPTION	BOTTOM TRAY CLAMP 50SWB	819
819-MMMM 31 MMMM	Clamp, Bottom Tray #50SWB, Mat'l, 10 Ga, w/ 3/8" X 2" welded bolt, Mat'l		
819-MMMM 311 MMMM	Clamp, Bottom Tray #50SWB, Mat'l, 10 Ga, w/ 1/2" X 2" welded bolt, Mat'l		

Replaces the old Bottom Tray Clamps #13 Series.
Available with other bolt lengths upon request.

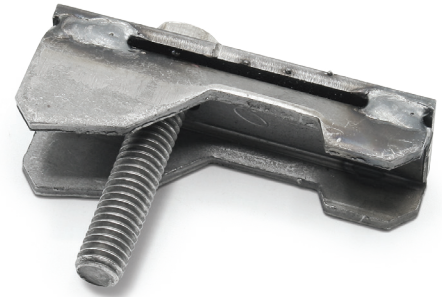

ITEM NO.	ITEM DESCRIPTION	BOTTOM TRAY CLAMP #EM	404 406
404-MMMM 10	Clamp, Bottom Tray #EM, Mat'l, 14 Ga, 7/16" Hole		
406-MMMM 10 MMMM	*Clamp, Bottom Tray #EM, Mat'l, 14 Ga, w/ 3/8" X 2" welded bolt, MMMM		

Clamps EM are for use with exotic materials (specifically Titanium and Zirconium) and replace the Y-Clamp and YB-Clamp.

* Available with other bolt lengths upon request.

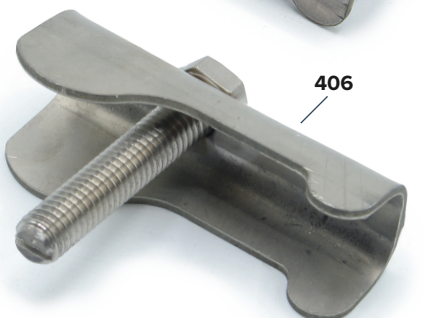

NON-STANDARD HARDWARE ITEMS

- 850-MMMM 2050
Insert Material identification number from chart on p. 6.
- Clamp, Bottom Tray #20-E, Mat'l, 12 Ga, 1/2" Tab, 7/16" Hole
Insert abbreviated Material name from p. 6.

ITEM NO.	ITEM DESCRIPTION	BOTTOM TRAY CLAMPS #20 SERIES	850 852 853 854 855 856
850-MMMM 2050	Clamp, Bottom Tray #20-E, Mat'l, 12 Ga, 1/2" Tab, 7/16" Hole		
852-MMMM 051 MMMM	Clamp, Bottom Tray #22-E, Mat'l, 12 Ga, 1/2" Tab, 3/8" Nut, Mat'l		
853-MMMM 051 MMMM	Clamp, Bottom Tray #23-E, Mat'l, 12 Ga, 1/2" Tab, 3/8 x 2" Bolt, Mat'l		
854-MMMM 2050	Clamp, Bottom Tray #24-E, Mat'l, 12 Ga, 1/2" Tab, 7/16" Hole		
855-MMMM 051 MMMM	Clamp, Bottom Tray #26-E, Mat'l, 12 Ga, 1/2" Tab, 3/8" Nut, Mat'l		
856-MMMM 051 MMMM	Clamp, Bottom Tray #27-E, Mat'l, 12 Ga, 1/2" Tab, 3/8 x 2" Bolt, Mat'l		



Note: All Bottom Tray Clamps in the #20 series are available as a special order item.
Please specify part #, Ex. 20-E, 22-E, 23-E or tab height.

Our new Bottom Tray Clamps "Y" series replaces the old Bottom Tray Clamps #20 Series.

* 902 BTC "Y" replaces BTC #20 series with open Hole.

* 946 BTC "YN" replaces BTC #20 series with welded nut.

* 932 BTC "YB" replaces BTC #20 series with welded bolt.

BTC "Y" series are shown in the standard section.

ITEM NO.	ITEM DESCRIPTION	BOTTOM TRAY CLAMPS #10A-10P	857
857-MMMM 010	Clamp, Bottom Tray #10A, Mat'l, 3/8" Tab length, 7/16" Hole		
857-MMMM 020	Clamp, Bottom Tray #10B, Mat'l, 7/16" Tab length, 7/16" Hole		
857-MMMM 030	Clamp, Bottom Tray #10C, Mat'l, 1/2" Tab length, 7/16" Hole		
857-MMMM 040	Clamp, Bottom Tray #10D, Mat'l, 5/8" Tab length, 7/16" Hole		
857-MMMM 050	Clamp, Bottom Tray #10E, Mat'l, 3/4" Tab length, 7/16" Hole		
857-MMMM 060	Clamp, Bottom Tray #10F, Mat'l, 7/8" Tab length, 7/16" Hole		
857-MMMM 070	Clamp, Bottom Tray #10G, Mat'l, 1" Tab length, 7/16" Hole		
857-MMMM 080	Clamp, Bottom Tray #10H, Mat'l, 1-1/8" Tab length, 7/16" Hole		
857-MMMM 090	Clamp, Bottom Tray #10J, Mat'l, 1-1/4" Tab length, 7/16" Hole		
857-MMMM 100	Clamp, Bottom Tray #10K, Mat'l, 1-3/8" Tab length, 7/16" Hole		
857-MMMM 110	Clamp, Bottom Tray #10L, Mat'l, 1-1/2" Tab length, 7/16" Hole		
857-MMMM 120	Clamp, Bottom Tray #10M, Mat'l, 1-5/8" Tab length, 7/16" Hole		
858-MMMM 130	Clamp, Bottom Tray #10N, Mat'l, 1-3/4" Tab length, 7/16" Hole		
857-MMMM 140	Clamp, Bottom Tray #10O, Mat'l, 1-7/8" Tab length, 7/16" Hole		
857-MMMM 150	Clamp, Bottom Tray #10P, Mat'l, 2" Tab length, 7/16" Hole		



Bottom Tray Clamp #10 is also available with 9/16" Hole.

*Our new Bottom Tray Clamps "50SWN" series replaces the old Bottom Tray Clamps #10A-10P Series.

50SWN Clamps are shown in the Non-Standard Section.

ITEM NO.	ITEM DESCRIPTION	BOTTOM TRAY CLAMPS #12A-12N	858
858-MMMM 011 MMMM	Clamp, Bottom Tray #12A, Mat'l, 3/8" Tab length, 3/8"x 16 UNC-2B Nut, Mat'l		
858-MMMM 021 MMMM	Clamp, Bottom Tray #12B, Mat'l, 7/16" Tab length, 3/8"x 16 UNC-2B Nut, Mat'l		
858-MMMM 031 MMMM	Clamp, Bottom Tray #12C, Mat'l, 1/2" Tab length, 3/8"x 16 UNC-2B Nut, Mat'l		
858-MMMM 041 MMMM	Clamp, Bottom Tray #12D, Mat'l, 5/8" Tab length, 3/8"x 16 UNC-2B Nut, Mat'l		
858-MMMM 051 MMMM	Clamp, Bottom Tray #12E, Mat'l, 3/4" Tab length, 3/8"x 16 UNC-2B Nut, Mat'l		
858-MMMM 061 MMMM	Clamp, Bottom Tray #12F, Mat'l, 7/8" Tab length, 3/8"x 16 UNC-2B Nut, Mat'l		
858-MMMM 071 MMMM	Clamp, Bottom Tray #12G, Mat'l, 1" Tab length, 3/8"x 16 UNC-2B Nut, Mat'l		
858-MMMM 081 MMMM	Clamp, Bottom Tray #12H, Mat'l, 1-1/8" Tab length, 3/8"x 16 UNC-2B Nut, Mat'l		
858-MMMM 091 MMMM	Clamp, Bottom Tray #12J, Mat'l, 1-1/4" Tab length, 3/8"x 16 UNC-2B Nut, Mat'l		
858-MMMM 101 MMMM	Clamp, Bottom Tray #12K, Mat'l, 1-3/8" Tab length, 3/8"x 16 UNC-2B Nut, Mat'l		
858-MMMM 111 MMMM	Clamp, Bottom Tray #12L, Mat'l, 1-1/2" Tab length, 3/8"x 16 UNC-2B Nut, Mat'l		
858-MMMM 121 MMMM	Clamp, Bottom Tray #12M, Mat'l, 1-5/8" Tab length, 3/8"x 16 UNC-2B Nut, Mat'l		
858-MMMM 131 MMMM	Clamp, Bottom Tray #12N, Mat'l, 1-3/4" Tab length, 3/8"x 16 UNC-2B Nut, Mat'l		



Bottom Tray Clamp #12 is also available with other size welded nuts.

*Our new Bottom Tray Clamps "50SWN" series replaces the old Bottom Tray Clamps #12A-12N Series.

50SWN Clamps are shown in the Non-Standard Section

- 859-MMMM 011 MMMM
- Insert Material identification number from chart on p. 6.
- Clamp, Bottom Tray #13A, Mat'l, 3/8" Tab length, 3/8"-16 UNC-2A x 2" Bolt, Mat'l
- Insert abbreviated Material name from p. 6.

NON-STANDARD HARDWARE ITEMS

ITEM NO.	ITEM DESCRIPTION	BOTTOM TRAY CLAMPS #13A-13P	859
859-MMMM 011 MMMM	Clamp, Bottom Tray #13A, Mat'l, 3/8" Tab length, 3/8"-16 UNC-2A x 2" Bolt, Mat'l		
859-MMMM 021 MMMM	Clamp, Bottom Tray #13B, Mat'l, 7/16" Tab length, 3/8"-16 UNC-2A x 2" Bolt, Mat'l		
859-MMMM 031 MMMM	Clamp, Bottom Tray #13C, Mat'l, 1/2" Tab length, 3/8"-16 UNC-2A x 2" Bolt, Mat'l		
859-MMMM 041 MMMM	Clamp, Bottom Tray #13D, Mat'l, 5/8" Tab length, 3/8"-16 UNC-2A x 2-1/2" Bolt, Mat'l		
859-MMMM 051 MMMM	Clamp, Bottom Tray #13E, Mat'l, 3/4" Tab length, 3/8"-16 UNC-2A x 2-1/2" Bolt, Mat'l		
859-MMMM 061 MMMM	Clamp, Bottom Tray #13F, Mat'l, 7/8" Tab length, 3/8"-16 UNC-2A x 2-1/2" Bolt, Mat'l		
859-MMMM 071 MMMM	Clamp, Bottom Tray #13G, Mat'l, 1" Tab length, 3/8"-16 UNC-2A x 2-1/2" Bolt, Mat'l		
859-MMMM 081 MMMM	Clamp, Bottom Tray #13H, Mat'l, 1-1/8" Tab length, 3/8"-16 UNC-2A x 3" Bolt, Mat'l		
859-MMMM 091 MMMM	Clamp, Bottom Tray #13J, Mat'l, 1-1/4" Tab length, 3/8"-16 UNC-2A x 3" Bolt, Mat'l		
859-MMMM 101 MMMM	Clamp, Bottom Tray #13K, Mat'l, 1-3/8" Tab length, 3/8"-16 UNC-2A x 3" Bolt, Mat'l		
859-MMMM 111 MMMM	Clamp, Bottom Tray #13L, Mat'l, 1-1/2" Tab length, 3/8"-16 UNC-2A x 3" Bolt, Mat'l		
859-MMMM 121 MMMM	Clamp, Bottom Tray #13M, Mat'l, 1-5/8" Tab length, 3/8"-16 UNC-2A x 3-1/2" Bolt, Mat'l		
859-MMMM 131 MMMM	Clamp, Bottom Tray #13N, Mat'l, 1-3/4" Tab length, 3/8"-16 UNC-2A x 3-1/2" Bolt, Mat'l		
859-MMMM 141 MMMM	Clamp, Bottom Tray #13O, Mat'l, 1-7/8" Tab length, 3/8"-16 UNC-2A x 3-1/2" Bolt, Mat'l		
859-MMMM 151 MMMM	Clamp, Bottom Tray #13P, Mat'l, 2" Tab length, 3/8"-16 UNC-2A x 3-1/2" Bolt, Mat'l		



Bottom Tray Clamp #13 is also available with other size bolts.

*Our new Bottom Tray Clamps "50SWB" series replaces the old Bottom Tray Clamps #13A-13P Series. 50SWB Clamps are shown in the Non-Standard Section.

ITEM NO.	ITEM DESCRIPTION	BOTTOM TRAY CLAMP #7	849
849-MMMM 1 MMMM	Clamp, Bottom Tray #7, Mat'l, 1/4"t, 3/8"-16 UNC-2A Stud, Mat'l		



ITEM NO.	ITEM DESCRIPTION	UNIVERSAL LEVER CLAMPS #1	315 331
315-MMMM 0	Clamp, Universal Lever #1, Mat'l, 14 Ga, 13/32" Hole		
315-MMMM 1	Clamp, Universal Lever #1, Mat'l, 12 Ga, 13/32" Hole		
315-MMMM 2	Clamp, Universal Lever #1, Mat'l, 11 Ga, 13/32" Hole		

ITEM #331

Single Lever Clamp #1 is available with welded bolt. Specify bolt diameter and length when ordering.

Our new Bottom Tray Clamp "Y" series replaces the old Single Lever Clamp #1.

*902 BTC "Y" replaces the Single Lever Clamp #1 with open Hole (See Standard Section).

*932 BTC "YB" replaces the Single Lever Clamp #1 with bolt (See Standard Section).



ITEM NO.	ITEM DESCRIPTION	UNIVERSAL LEVER CLAMPS #3	317 333
317-MMMM	Clamp, Universal Lever #3, Mat'l, 14 Ga, 13/32" Hole		

ITEM #333

Single Lever Clamp #3 is available with welded bolt. Specify bolt diameter and length when ordering.

Our new Bottom Tray Clamp "Y" series replaces the old Single Lever Clamp #3.

*902 BTC "Y" replaces the Single Lever Clamp #3 with open Hole (See Standard Section).

*932 BTC "YB" replaces the Single Lever Clamp #3 with bolt (See Standard Section).



ITEM NO.	ITEM DESCRIPTION	SINGLE LEVER CLAMPS	322
322-MMMM 011	Clamp, Single Lever, Mat'l, 10 Ga, 5/16" Tab length, 3/8"-16 UNC-2B Tapped Hole		
322-MMMM 012	Clamp, Single Lever, Mat'l, 10 Ga, 5/16" Tab length, 7/16" Hole		
322-MMMM 031	Clamp, Single Lever, Mat'l, 12 Ga, 9/16" Tab length, 3/8"-16 UNC-2B Tapped Hole		
322-MMMM 132	Clamp, Single Lever, Mat'l, 12 Ga, 9/16" Tab length, 7/16" Hole		
322-MMMM 251	Clamp, Single Lever, Mat'l, 11 Ga, 13/16" Tab length, 3/8"-16 UNC-2B Tapped Hole		
322-MMMM 252	Clamp, Single Lever, Mat'l, 11 Ga, 13/16" Tab length, 7/16" Hole		



Single Lever Clamp is available with additional tab lengths and hole sizes upon request.

Our new Bottom Tray Clamp "Y" series replaces the old Single Lever Clamp.

*902 BTC "Y" replaces the Single Lever Clamp with open Hole (See Standard Section).

*946 BTC "YN" replaces the Single Lever Clamp with tapped Hole (See Standard Section).

NON-STANDARD HARDWARE ITEMS

- ↳ 871-MMMM 210
Insert Material identification number from chart on p. 6.
- ↳ Clamp, Top Tray #1, Mat'l, 12 Ga, 2-3/8" LG, w/ 7/16" Hole
Insert abbreviated Material name from p. 6.

ITEM NO.	ITEM DESCRIPTION	TOP TRAY CLAMPS #1 & 2	871
871-MMMM 210	Clamp, Top Tray #1, Mat'l, 12 Ga, 2-3/8" LG, w/ 7/16" Hole		
871-MMMM 220	Clamp, Top Tray #2, Mat'l, 12 Ga, 2-7/8" LG, w/ 7/16" Hole		
871-MMMM 310	*Clamp, Top Tray #1, Mat'l, 10 Ga, 2-3/8" LG, w/ 7/16" Hole		
871-MMMM 320	*Clamp, Top Tray #2, Mat'l, 10 Ga, 2-7/8" LG, w/ 7/16" Hole		

*Available in C.S.

ITEM NO.	ITEM DESCRIPTION	TRAY FLOOR CLAMPS #L-2 & L-4	870
870-MMMM 1	Clamp, Tray Floor #L-2, Mat'l, 14 Ga		
870-MMMM 2	Clamp, Tray Floor #L-4, Mat'l, 12 Ga		

ITEM NO.	ITEM DESCRIPTION	BOTTOM CLAMPS #4	846
846-MMMM 21	Clamp, Bottom #4, Mat'l, 12 Ga, 5/16" Lip		
846-MMMM 22	Clamp, Bottom #4-1, Mat'l, 12 Ga, 7/16" Lip		
846-MMMM 23	Clamp, Bottom #4-2, Mat'l, 12 Ga, 9/16" Lip		
846-MMMM 31	*Clamp, Bottom #4, Mat'l, 10 Ga, 5/16" Lip		
846-MMMM 32	*Clamp, Bottom #4-1, Mat'l, 10 Ga, 7/16" Lip		
846-MMMM 33	*Clamp, Bottom #4-2, Mat'l, 10 Ga, 9/16" Lip		

*Available in C.S.

ITEM NO.	ITEM DESCRIPTION	BOTTOM CLAMPS #6, 7 & 8	836
836-MMMM 21	Clamp, Bottom #6, Mat'l, 12 Ga, 1/8" Lip		
836-MMMM 22	Clamp, Bottom #7, Mat'l, 12 Ga, 3/16" Lip		
836-MMMM 23	Clamp, Bottom #8, Mat'l, 12 Ga, 5/16" Lip		
836-MMMM 31	*Clamp, Bottom #6, Mat'l, 10 Ga, 1/8" Lip		
836-MMMM 32	*Clamp, Bottom #7, Mat'l, 10 Ga, 3/16" Lip		
836-MMMM 33	*Clamp, Bottom #8, Mat'l, 10 Ga, 5/16" Lip		

*Available in C.S.

ITEM NO.	ITEM DESCRIPTION	BOTTOM CLAMPS #9	842
842-MMMM 202	Clamp, Bottom #9, Mat'l, 12 Ga, 1/2" Tab length		
842-MMMM 302	*Clamp, Bottom #9, Mat'l, 10 Ga, 1/2" Tab length		

*Available in C.S.

ITEM NO.	ITEM DESCRIPTION	BOTTOM CLAMPS #12	872
872-MMMM 51	Clamp, Bottom #12, Mat'l, 1/4"t, 30 deg. Angle (SBC-1)		
872-MMMM 52	Clamp, Bottom #12, Mat'l, 1/4"t, 45 deg. Angle (SBC-2)		

Available in other thicknesses.

ITEM NO.	ITEM DESCRIPTION	DOUBLE BAR CLAMPS	341
341-MMMM 001	Clamp, Double Bar, Mat'l, 10 Ga, 3-1/2" Hole spacing, 3/8"-16 UNC-2B Tapped Hole		
341-MMMM 101	Clamp, Double Bar, Mat'l, 12 Ga, 3-1/2" Hole spacing, 3/8"-16 UNC-2B Tapped Hole		
341-MMMM 011	Clamp, Double Bar, Mat'l, 10 Ga, 4" Hole spacing, 3/8"-16 UNC-2B Tapped Hole		
341-MMMM 111	Clamp, Double Bar, Mat'l, 12 Ga, 4" Hole spacing, 3/8"-16 UNC-2B Tapped Hole		
341-MMMM 021	Clamp, Double Bar, Mat'l, 10 Ga, 4-1/2" Hole spacing, 3/8"-16 UNC-2B Tapped Hole		
341-MMMM 121	Clamp, Double Bar, Mat'l, 12 Ga, 4-1/2" Hole spacing, 3/8"-16 UNC-2B Tapped Hole		

Double Bar Clamps are available with additional hole spacings (please specify) and with open holes.

- 343-MMMM 0011
- Insert Material identification number from chart on p. 6.
- **Clamp, Double Lever, Mat'l, 10 Ga, 3-1/2" Hole spacing, 5/16" Tab length, 3/8"-16 UNC-2B Tapped Hole**
- Insert abbreviated Material name from p. 6.

NON-STANDARD HARDWARE ITEMS

ITEM NO.	ITEM DESCRIPTION	DOUBLE LEVER CLAMPS	343
343-MMMM 0011	Clamp, Double Lever, Mat'l, 10 Ga, 3-1/2" Hole spacing, 5/16" Tab length, 3/8"-16 UNC-2B Tapped Hole		
343-MMMM 1011	Clamp, Double Lever, Mat'l, 12 Ga, 3-1/2" Hole spacing, 5/16" Tab length, 3/8"-16 UNC-2B Tapped Hole		
343-MMMM 0121	Clamp, Double Lever, Mat'l, 10 Ga, 4" Hole spacing, 7/16" Tab length, 3/8"-16 UNC-2B Tapped Hole		
343-MMMM 1121	Clamp, Double Lever, Mat'l, 12 Ga, 4" Hole spacing, 7/16" Tab length, 3/8"-16 UNC-2B Tapped Hole		

Double Lever Clamps are available with other hole spacings, tab lengths, and with 7/16" holes. Please specify when ordering.

ITEM NO.	ITEM DESCRIPTION	MANWAY LOCK CLAMP #65	861
861-MMMM 2	Clamp, Manway Lock #65, Mat'l, 1/4"t, for 1/2" Stud		



ITEM NO.	ITEM DESCRIPTION	MANWAY LOCK CLAMPS #30	862
862-MMMM 4	Clamp, Manway Lock #30, Mat'l, 3/16"t, for 3/8" Stud		
862-MMMM 5	* Clamp, Manway Lock #30, Mat'l, 1/4"t, for 3/8" Stud		

**Available in C.S.*

ITEM NO.	ITEM DESCRIPTION	MANWAY LOCK CLAMPS #40A-P	864
864-MMMM 201	Clamp, Manway Lock #40A, Mat'l, 12 Ga, 3/16" Lip		
864-MMMM 204	Clamp, Manway Lock #40D, Mat'l, 12 Ga, 3/8" Lip		
864-MMMM 209	Clamp, Manway Lock #40J, Mat'l, 12 Ga, 1" Lip		
864-MMMM 215	Clamp, Manway Lock #40P, Mat'l, 12 Ga, 1-3/4" Lip		
864-MMMM 301	* Clamp, Manway Lock #40A, Mat'l, 10 Ga, 3/16" Lip		
864-MMMM 304	* Clamp, Manway Lock #40D, Mat'l, 10 Ga, 3/8" Lip		
864-MMMM 309	* Clamp, Manway Lock #40J, Mat'l, 10 Ga, 1" Lip		
864-MMMM 315	* Clamp, Manway Lock #40P, Mat'l, 10 Ga, 1-3/4" Lip		

**Available in C.S.*

Other sizes available in lip lengths with 1/16" increments.

903 BTC "YD" Replaces Manway Lock Clamp #40.

BTC "YD" is shown in the Standard Section.

ITEM NO.	ITEM DESCRIPTION	MANWAY LOCK CLAMPS #50A-50N	828
828-MMMM 012	Clamp, Manway Lock #50A, Mat'l, 3/8" Tab length, Hole for 3/8" "D" shape Manway Stud		
828-MMMM 022	Clamp, Manway Lock #50B, Mat'l, 7/16" Tab length, Hole for 3/8" "D" shape Manway Stud		
828-MMMM 032	Clamp, Manway Lock #50C, Mat'l, 1/2" Tab length, Hole for 3/8" "D" shape Manway Stud		
828-MMMM 042	Clamp, Manway Lock #50D, Mat'l, 5/8" Tab length, Hole for 3/8" "D" shape Manway Stud		
828-MMMM 052	Clamp, Manway Lock #50E, Mat'l, 3/4" Tab length, Hole for 3/8" "D" shape Manway Stud		
828-MMMM 062	Clamp, Manway Lock #50F, Mat'l, 7/8" Tab length, Hole for 3/8" "D" shape Manway Stud		
828-MMMM 072	Clamp, Manway Lock #50G, Mat'l, 1" Tab length, Hole for 3/8" "D" shape Manway Stud		
828-MMMM 082	Clamp, Manway Lock #50H, Mat'l, 1-1/8" Tab length, Hole for 3/8" "D" shape Manway Stud		
828-MMMM 092	Clamp, Manway Lock #50J, Mat'l, 1-1/4" Tab length, Hole for 3/8" "D" shape Manway Stud		
828-MMMM 102	Clamp, Manway Lock #50K, Mat'l, 1-3/8" Tab length, Hole for 3/8" "D" shape Manway Stud		
828-MMMM 112	Clamp, Manway Lock #50L, Mat'l, 1-1/2" Tab length, Hole for 3/8" "D" shape Manway Stud		
828-MMMM 122	Clamp, Manway Lock #50M, Mat'l, 1-5/8" Tab length, Hole for 3/8" "D" shape Manway Stud		
828-MMMM 132	Clamp, Manway Lock #50N, Mat'l, 1-3/4" Tab length, Hole for 3/8" "D" shape Manway Stud		

Available with other size holes.

NON-STANDARD HARDWARE ITEMS

- ↳ 829-MMMM 2
Insert Material identification number from chart on p. 6.
- ↳ Clamp, Manway Lock #55, Mat'l, for 3/8" Stud
Insert abbreviated Material name from p. 6.

ITEM NO.	ITEM DESCRIPTION	MANWAY LOCK CLAMP #55	829
829-MMMM 2	Clamp, Manway Lock #55, Mat'l, for 3/8" Stud		



ITEM NO.	ITEM DESCRIPTION	MANWAY LOCK CLAMPS #60	868
868-MMMM 4	Clamp, Manway Lock #60, Mat'l, 3/16"t, for 1/2" Stud		
868-MMMM 5	*Clamp, Manway Lock #60, Mat'l, 1/4"t, for 1/2" Stud		

*Available in C.S.

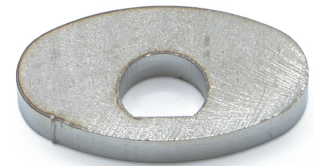

ITEM NO.	ITEM DESCRIPTION	MANWAY LOCK CLAMPS #2-K THRU 2-V & 3-K THRU 3-V	869
869-MMMM 012	Clamp, Manway Lock #2-K, Mat'l, 1/4"t, w/ 1/16" Dimple		
869-MMMM 013	Clamp, Manway Lock #3-K, Mat'l, 3/16"t, w/ 1/16" Dimple		
869-MMMM 042	Clamp, Manway Lock #2-N, Mat'l, 1/4"t, w/ 1/4" Tab		
869-MMMM 043	Clamp, Manway Lock #3-N, Mat'l, 3/16"t, w/ 1/4" Tab		
869-MMMM 062	Clamp, Manway Lock #2-P, Mat'l, 1/4"t, w/ 3/8" Tab		
869-MMMM 063	Clamp, Manway Lock #3-P, Mat'l, 3/16"t, w/ 3/8" Tab		
869-MMMM 082	Clamp, Manway Lock #2-R, Mat'l, 1/4"t, w/ 1/2" Tab		
869-MMMM 083	Clamp, Manway Lock #3-R, Mat'l, 3/16"t, w/ 1/2" Tab		
869-MMMM 122	Clamp, Manway Lock #2-V, Mat'l, 1/4"t, w/ 3/4" Tab		
869-MMMM 123	Clamp, Manway Lock #3-V, Mat'l, 3/16"t, w/ 3/4" Tab		

Other material types, Hole dimensions and tab length (in 1/16" increments) available upon request.
C.S. available in 1/4" thickness



ITEM NO.	ITEM DESCRIPTION	MANWAY LOCK CLAMPS #4	873
873-MMMM 4	Clamp, Manway Lock #4, Mat'l, 3/16"t		
873-MMMM 5	Clamp, Manway Lock #4, Mat'l, 1/4"t		



ITEM NO.	ITEM DESCRIPTION	MANWAY WASHER	301
301-MMMM 306	Washer, Manway, Mat'l, 12 Ga, 2" od w/ hole for 3/8" "D" shape Manway Stud		

Available with other outside diameters, hole sizes and thicknesses.



- 840-MMMM 011 MMMM
Insert Material identification number from chart on p. 6.
- Clamp, Support Grid #2, Mat'l, 3/16" Tab length, 4" LG Stud, 12 Ga, 3/8"-16 UNC-2A, Stud Mat'l
Insert abbreviated Material name from p. 6.

NON-STANDARD HARDWARE ITEMS

ITEM NO.	ITEM DESCRIPTION	SUPPORT GRID CLAMPS #2	840
840-MMMM 011 MMMM	Clamp, Support Grid #2, Mat'l, 3/16" Tab length, 4" LG Stud, 12 Ga, 3/8"-16 UNC-2A, Stud Mat'l		
840-MMMM 021 MMMM	Clamp, Support Grid #2, Mat'l, 1/4" Tab length, 4" LG Stud, 12 Ga, 3/8"-16 UNC-2A, Stud Mat'l		
840-MMMM 031 MMMM	Clamp, Support Grid #2, Mat'l, 5/16" Tab length, 4" LG Stud, 12 Ga, 3/8"-16 UNC-2A, Stud Mat'l		
840-MMMM 041 MMMM	Clamp, Support Grid #2, Mat'l, 3/8" Tab length, 4" LG Stud, 12 Ga, 3/8"-16 UNC-2A, Stud Mat'l		
840-MMMM 051 MMMM	Clamp, Support Grid #2, Mat'l, 1/2" Tab length, 4" LG Stud, 12 Ga, 3/8"-16 UNC-2A, Stud Mat'l		
840-MMMM 061 MMMM	Clamp, Support Grid #2, Mat'l, 5/8" Tab length, 4-1/2" LG Stud, 12 Ga, 3/8"-16 UNC-2A, Stud Mat'l		
840-MMMM 071 MMMM	Clamp, Support Grid #2, Mat'l, 3/4" Tab length, 4-1/2" LG Stud, 12 Ga, 3/8"-16 UNC-2A, Stud Mat'l		
840-MMMM 081 MMMM	Clamp, Support Grid #2, Mat'l, 7/8" Tab length, 4-1/2" LG Stud, 12 Ga, 3/8"-16 UNC-2A, Stud Mat'l		
840-MMMM 091 MMMM	Clamp, Support Grid #2, Mat'l, 1" Tab length, 4-1/2" LG Stud, 12 Ga, 3/8"-16 UNC-2A, Stud Mat'l		
840-MMMM 101 MMMM	Clamp, Support Grid #2, Mat'l, 1-1/8" Tab length, 5" LG Stud, 12 Ga, 3/8"-16 UNC-2A, Stud Mat'l		
840-MMMM 111 MMMM	Clamp, Support Grid #2, Mat'l, 1-1/4" Tab length, 5" LG Stud, 12 Ga, 3/8"-16 UNC-2A, Stud Mat'l		
840-MMMM 121 MMMM	Clamp, Support Grid #2, Mat'l, 1-3/8" Tab length, 5" LG Stud, 12 Ga, 3/8"-16 UNC-2A, Stud Mat'l		
840-MMMM 131 MMMM	Clamp, Support Grid #2, Mat'l, 1-1/2" Tab length, 5" LG Stud, 12 Ga, 3/8"-16 UNC-2A, Stud Mat'l		



Available in other thicknesses and stud diameters.

ITEM NO.	ITEM DESCRIPTION	GRID HOLDDOWN CLIP #3	878
878-MMMM	Clip, Grid Holddown #3, Mat'l		



ITEM NO.	ITEM DESCRIPTION	HOOK BOLT #1	888
888-MMMM 14016	Hook Bolt #1, Mat'l, 3/8"-16UNC-2A x 10" length (4" thread length)		

Available in other bolt / thread lengths upon request.



ITEM NO.	ITEM DESCRIPTION	HOLDDOWN PLATES #1 & 2	887
887-MMMM 11	Plate, Holddown #1, Mat'l, 14 Ga, 4" wide plate		
887-MMMM 21	Plate, Holddown #1, Mat'l, 12 Ga, 4" wide plate		
887-MMMM 31	Plate, Holddown #1, Mat'l, 10 Ga, 4" wide plate		
887-MMMM 41	Plate, Holddown #1, Mat'l, 3/16"t, 4" wide plate		
887-MMMM 51	Plate, Holddown #1, Mat'l, 1/4"t, 4" wide plate		
887-MMMM 12	Plate, Holddown #2, Mat'l, 14 Ga, 2" wide plate		
887-MMMM 22	Plate, Holddown #2, Mat'l, 12 Ga, 2" wide plate		
887-MMMM 32	Plate, Holddown #2, Mat'l, 10 Ga, 2" wide plate		
887-MMMM 42	Plate, Holddown #2, Mat'l, 3/16"t, 2" wide plate		
887-MMMM 52	Plate, Holddown #2, Mat'l, 1/4"t, 2" wide plate		

Available in other bolt / thread lengths upon request.



ITEM NO.	ITEM DESCRIPTION	ANGLE HANGERS #10, 10S, 20 & 20S	815 816
815-MMMM 21	Hanger, Angle #10, Mat'l, 12 Ga, 7/16" Hole, 5" LG		
815-MMMM 22	Hanger, Angle #20, Mat'l, 12 Ga, 7/16" Hole, 6" LG		
815-MMMM 31	*Hanger, Angle #10, Mat'l, 10 Ga, 7/16" Hole, 5" LG		
815-MMMM 32	*Hanger, Angle #20, Mat'l, 10 Ga, 7/16" Hole, 6" LG		
816-MMMM 21	Hanger, Angle #10S, Mat'l, 12 Ga, 7/16" Hole, 4-1/4" LG		
816-MMMM 22	Hanger, Angle #20S, Mat'l, 12 Ga, 7/16" Hole, 5-1/4" LG		
816-MMMM 31	*Hanger, Angle #10S, Mat'l, 10 Ga, 7/16" Hole, 4-1/4" LG		
816-MMMM 32	*Hanger, Angle #20S, Mat'l, 10 Ga, 7/16" Hole, 5-1/4" LG		



*Available in C.S.

Note: the #10S and #20S has a 3/4" modification to accommodate design requirements. (See photo for details).

NON-STANDARD HARDWARE ITEMS

- ↳ 833-MMMM 206 MMMM
Insert Material identification number from chart on p. 6.
- ↳ Hanger, Top Truss #6, Mat'l, 12 Ga, 3/8" Tab with Stud, Mat'l
Insert abbreviated Material name from p. 6.

ITEM NO.	ITEM DESCRIPTION	TOP TRUSS HANGERS #6 THRU 10	833
833-MMMM 206 MMMM	Hanger, Top Truss #6, Mat'l, 12 Ga, 3/8" Tab with Stud, Mat'l		
833-MMMM 207 MMMM	Hanger, Top Truss #7, Mat'l, 12 Ga, 1/2" Tab with Stud, Mat'l		
833-MMMM 208 MMMM	Hanger, Top Truss #8, Mat'l, 12 Ga, 5/8" Tab with Stud, Mat'l		
833-MMMM 209 MMMM	Hanger, Top Truss #9, Mat'l, 12 Ga, 3/4" Tab with Stud, Mat'l		
833-MMMM 210 MMMM	Hanger, Top Truss #10, Mat'l, 12 Ga, 7/8" Tab with Stud, Mat'l		
833-MMMM 306 MMMM	Hanger, Top Truss #6, Mat'l, 10 Ga, 3/8" Tab with Stud, Mat'l		
833-MMMM 307 MMMM	Hanger, Top Truss #7, Mat'l, 10 Ga, 1/2" Tab with Stud, Mat'l		
833-MMMM 308 MMMM	Hanger, Top Truss #8, Mat'l, 10 Ga, 5/8" Tab with Stud, Mat'l		
833-MMMM 309 MMMM	Hanger, Top Truss #9, Mat'l, 10 Ga, 3/4" Tab with Stud, Mat'l		
833-MMMM 310 MMMM	Hanger, Top Truss #10, Mat'l, 10 Ga, 7/8" Tab with Stud, Mat'l		



Note: Top Truss Hanger # 5 with an item 833-MMMM 205 or 833-MMMM 305 are without Studs.

ITEM NO.	ITEM DESCRIPTION	TOP TRUSS HANGER #12	834
834-MMMM	Hanger, Top Truss #12, Mat'l		



ITEM NO.	ITEM DESCRIPTION	"C" CLAMPS #1 THRU 7	875
875-MMMM 1	Clamp, "C", #1, Mat'l, 16 Ga, 11/16" Opening		
875-MMMM 2	Clamp, "C", #2, Mat'l, 16 Ga, 17/32" Opening		
875-MMMM 3	Clamp, "C", #3, Mat'l, 16 Ga, 1-5/16" Opening		
875-MMMM 4	Clamp, "C", #4, Mat'l, 16 Ga, 1-3/8" Opening		
875-MMMM 5	Clamp, "C", #5, Mat'l, 16 Ga, 27/32" Opening		
875-MMMM 6	Clamp, "C", #6, Mat'l, 16 Ga, 1-1/16" Opening		
875-MMMM 7	Clamp, "C", #7, Mat'l, 16 Ga, 1-7/32" Opening		



ITEM NO.	ITEM DESCRIPTION	TYPE "A" WASHERS	807
807-MMMM 21	Washer, Type A, Mat'l, 12 Ga, 1" Slot		
807-MMMM 22	Washer, Type A-1, Mat'l, 12 Ga, 1-1/4" Slot		
807-MMMM 31	Washer, Type A, Mat'l, 10 Ga, 1" Slot"		
807-MMMM 32	Washer, Type A-1, Mat'l 10 Ga, 1-1/4" Slot		



ITEM NO.	ITEM DESCRIPTION	TYPE "B" WASHERS	808
808-MMMM 2	Washer, Type B, Mat'l, 12 Ga		
808-MMMM 3	Washer, Type B, Mat'l, 10 Ga		



ITEM NO.	ITEM DESCRIPTION	WEDGE #6	823
823-MMMM	Wedge #6, Mat'l		



ITEM NO.	ITEM DESCRIPTION	WEDGE #10	824
824-MMMM	Wedge #10, Mat'l		



- 600-MMMM 1620
Insert Material identification number from chart on p. 6.
- Ballast Unit V-1 & GV-1, Mat'l, 3/8" (9.53mm) leg length, 20 Ga (1mm)
Insert abbreviated Material name from p. 6.

NON-STANDARD HARDWARE ITEMS

ITEM NO.	ITEM DESCRIPTION	BALLAST® UNITS V-1, GV-1, V-1H, GV-1H, V-4 & V-4H	600
600-MMMM 1620	Ballast Unit V-1 & GV-1, Mat'l, 3/8" (9.53mm) leg length, 20 Ga (1mm)		
600-MMMM 1618	Ballast Unit V-1 & GV-1, Mat'l, 3/8" (9.53mm) leg length, 18 Ga (1.2mm)		
600-MMMM 1616	Ballast Unit V-1 & GV-1, Mat'l, 3/8" (9.53mm) leg length, 16 Ga (1.5mm)		
600-MMMM 1614	Ballast Unit V-1 & GV-1, Mat'l, 3/8" (9.53mm) leg length, 14 Ga (2mm)		
600-MMMM 1612	Ballast Unit V-1H & GV-1H, Mat'l, 3/8" (9.53mm) leg length, 12 Ga (2.5mm)		
600-MMMM 1720	Ballast Unit V-1 & GV-1, Mat'l, 7/16" (11.11mm) leg length, 20 Ga (1mm)		
600-MMMM 1718	Ballast Unit V-1 & GV-1, Mat'l, 7/16" (11.11mm) leg length, 18 Ga (1.2mm)		
600-MMMM 1716	Ballast Unit V-1 & GV-1, Mat'l, 7/16" (11.11mm) leg length, 16 Ga (1.5mm)		
600-MMMM 1714	Ballast Unit V-1 & GV-1, Mat'l, 7/16" (11.11mm) leg length, 14 Ga (2mm)		
600-MMMM 1712	Ballast Unit V-1H & GV-1H, Mat'l, 7/16" (11.11mm) leg length, 12 Ga (2.5mm)		
600-MMMM 1820	Ballast Unit V-1 & GV-1, Mat'l, 1/2" (12.7mm) leg length, 20 Ga (1mm)		
600-MMMM 1818	Ballast Unit V-1 & GV-1, Mat'l, 1/2" (12.7mm) leg length, 18 Ga (1.2mm)		
600-MMMM 1816	Ballast Unit V-1 & GV-1, Mat'l, 1/2" (12.7mm) leg length, 16 Ga (1.5mm)		
600-MMMM 1814	Ballast Unit V-1 & GV-1, Mat'l, 1/2" (12.7mm) leg length, 14 Ga (2mm)		
600-MMMM 1812	Ballast Unit V-1H & GV-1H, Mat'l, 1/2" (12.7mm) leg length, 12 Ga (2.5mm)		
600-MMMM 1920	Ballast Unit V- 4 or V-1, Mat'l, 9/16" (14.29mm) leg length, 20 Ga (1mm)		
600-MMMM 1918	Ballast Unit V- 4 or V-1, Mat'l, 9/16" (14.29mm) leg length, 18 Ga (1.2mm)		
600-MMMM 1916	Ballast Unit V- 4 or V-1, Mat'l, 9/16" (14.29mm) leg length, 16 Ga (1.5mm)		
600-MMMM 1914	Ballast Unit V- 4 or V-1, Mat'l, 9/16" (14.29mm) leg length, 14 Ga (2mm)		
600-MMMM 1912	Ballast Unit V- 4H or V-1H, Mat'l, 9/16" (14.29mm) leg length, 12 Ga (2.5mm)*		
600-MMMM 1020	***Ballast Unit V-1 & GV-1, Mat'l, 5/8" (15.88mm) leg length, 20 Ga (1mm)		
600-MMMM 1018	***Ballast Unit V-1 & GV-1, Mat'l, 5/8" (15.88mm) leg length, 18 Ga (1.2mm)		
600-MMMM 1016	***Ballast Unit V-1 & GV-1, Mat'l, 5/8" (15.88mm) leg length, 16 Ga (1.5mm)		
600-MMMM 1014	***Ballast Unit V-1 & GV-1, Mat'l, 5/8" (15.88mm) leg length, 14 Ga (2mm)		
600-MMMM 1012	***Ballast Unit V-1H & GV-1H, Mat'l, 5/8" (15.88mm) leg length, 12 Ga (2.5mm)*		



***Europe Only.

Note: Our Part #307 A-Valves have replaced the 600 series Ballast Units. See Part 307 in the Standard section.

ITEM NO.	ITEM DESCRIPTION	BALLAST® UNITS V-1X, GV-1X, V-1XH, GV-1XH, V-4X & V-4XH	601
601-MMMM 2620	Ballast Unit V-1X & GV-1X (Flush Seat), Mat'l, 3/8" (9.53mm) leg length, 20 Ga (1mm)		
601-MMMM 2618	Ballast Unit V-1X & GV-1X (Flush Seat), Mat'l, 3/8" (9.53mm) leg length, 18 Ga (1.2mm)		
601-MMMM 2616	Ballast Unit V-1X & GV-1X (Flush Seat), Mat'l, 3/8" (9.53mm) leg length, 16 Ga (1.5mm)		
601-MMMM 2614	Ballast Unit V-1X & GV-1X (Flush Seat), Mat'l, 3/8" (9.53mm) leg length, 14 Ga (2mm)		
601-MMMM 2612	Ballast Unit V-1XH & GV-1XH (Flush Seat), Mat'l, 3/8" (9.53mm) leg length, 12 Ga (2.5mm)*		
601-MMMM 2720	Ballast Unit V-1X & GV-1X (Flush Seat), Mat'l, 7/16" (11.11mm) leg length, 20 Ga (1mm)		
601-MMMM 2718	Ballast Unit V-1X & GV-1X (Flush Seat), Mat'l, 7/16" (11.11mm) leg length, 18 Ga (1.2mm)		
601-MMMM 2716	Ballast Unit V-1X & GV-1X (Flush Seat), Mat'l, 7/16" (11.11mm) leg length, 16 Ga (1.5mm)		
601-MMMM 2714	Ballast Unit V-1X & GV-1X (Flush Seat), Mat'l, 7/16" (11.11mm) leg length, 14 Ga (2mm)		
601-MMMM 2712	Ballast Unit V-1XH & GV-1XH (Flush Seat), Mat'l, 7/16" (11.11mm) leg length, 12 Ga (2.5mm)*		
601-MMMM 2820	Ballast Unit V-1X & GV-1X (Flush Seat), Mat'l, 1/2" (12.7mm) leg length, 20 Ga (1mm)		
601-MMMM 2818	Ballast Unit V-1X & GV-1X (Flush Seat), Mat'l, 1/2" (12.7mm) leg length, 18 Ga (1.2mm)		
601-MMMM 2816	Ballast Unit V-1X & GV-1X (Flush Seat), Mat'l, 1/2" (12.7mm) leg length, 16 Ga (1.5mm)		
601-MMMM 2814	Ballast Unit V-1X & GV-1X (Flush Seat), Mat'l, 1/2" (12.7mm) leg length, 14 Ga (2mm)		
601-MMMM 2812	Ballast Unit V-1XH & GV-1XH (Flush Seat), Mat'l, 1/2" (12.7mm) leg length, 12 Ga (2.5mm)*		
601-MMMM 2920	Ballast Unit V-4X or V-1X (Flush Seat), Mat'l, 9/16" (14.29mm) leg length, 20 Ga (1mm)		
601-MMMM 2918	Ballast Unit V-4X or V-1X (Flush Seat), Mat'l, 9/16" (14.29mm) leg length, 18 Ga (1.2mm)		
601-MMMM 2916	Ballast Unit V-4X or V-1X (Flush Seat), Mat'l, 9/16" (14.29mm) leg length, 16 Ga (1.5mm)		
601-MMMM 2914	Ballast Unit V-4X or V-1X (Flush Seat), Mat'l, 9/16" (14.29mm) leg length, 14 Ga (2mm)		
601-MMMM 2912	Ballast Unit V-4XH or V-1XH (Flush Seat), Mat'l, 9/16" (14.29mm) leg length, 12 Ga (2.5mm)*		
601-MMMM 2020	***Ballast Unit V-1X & GV-1X (Flush Seat), Mat'l, 5/8" (15.88mm) leg length, 20 Ga (1mm)		
601-MMMM 2018	***Ballast Unit V-1X & GV-1X (Flush Seat), Mat'l, 5/8" (15.88mm) leg length, 18 Ga (1.2mm)		
601-MMMM 2016	***Ballast Unit V-1X & GV-1X (Flush Seat), Mat'l, 5/8" (15.88mm) leg length, 16 Ga (1.5mm)		
601-MMMM 2014	***Ballast Unit V-1X & GV-1X (Flush Seat), Mat'l, 5/8" (15.88mm) leg length, 14 Ga (2mm)		
601-MMMM 2012	***Ballast Unit V-1XH & GV-1XH (FlushSeat), Mat'l, 5/8" (15.88mm) leg length, 12 Ga (2.5mm)*		

***Europe Only.

Note: Our Part #308 A-Valves have replaced the 601 series Ballast Units. See Part 308 in the Standard section.



NON-STANDARD HARDWARE ITEMS

- ↳ **610-MMMM 2118**
Insert Material identification number from chart on p. 6.
- ↳ **Ballast Plate A-1, A-4, Mat'l, 18 Ga (1.2mm)**
Insert abbreviated Material name from p. 6.

TRAVEL STOP		611		
	A-1	A-2	A-2X	
	E = .074	E = .160	E = .160	
GAGE	1.9mm	4mm	4mm	
16	1.5mm	1116	1216	1216
14	2mm	1114	1214	1214
12	2.5mm	1112	1212	1212

E = "Tab" Depth (limits Ballast Plate rise)

BALLAST® PLATE		610		
	A-1	A-2	A-2X	
	A = 7/32"	A = 3/32"	A = 0	
GAGE	5.5mm	2.4mm		
18	1.2mm	2118	2218	2218
16	1.5mm	2116	2216	2216
14	2mm	2114	2214	2214
12	2.5mm	2112	2212	2212

A = Ballast Plate Leg Length

ORIFICE COVER (A-1 Units Only)		612		
GAGE	FLAT	CORRUGATED	DIMPLED	
16	1.5mm	1116	1216	1216
14	2mm	1114	1214	1214
12	2.5mm	1112	1212	1212

** A-4, A-5, & A-5X are used with tray decks with extruded orifice.

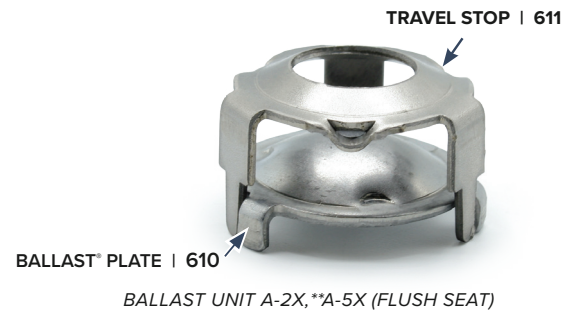
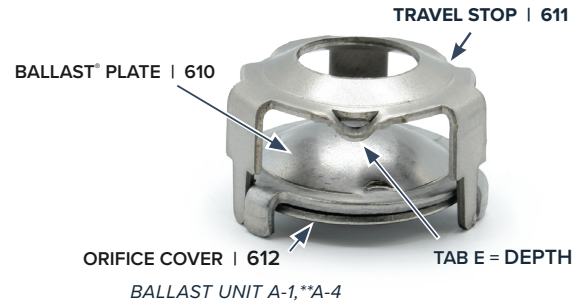

ITEM NO.	ITEM DESCRIPTION	BALLAST® PLATE	610
610-MMMM 2118	* Ballast Plate A-1, A-4, Mat'l, 18 Ga (1.2mm)		

* Specify from Ballast Plate (610) Chart.



ITEM NO.	ITEM DESCRIPTION	TRAVEL STOP	611
611-MMMM 1116	* Travel Stop A-1, A-4, Mat'l, 16 Ga (1.5mm)		

* Specify from Travel Stop (611) Chart.



ITEM NO.	ITEM DESCRIPTION	ORIFICE COVER	612
612-MMMM 3118	* Orifice Cover A-1, Mat'l, 18 Ga (1.2mm)		

* Specify from Orifice Cover (612) Chart.



- **893-MMMM 21**
Insert Material identification number from chart on p. 6.
- **Nut, Caged, Mat'l, for 14 Ga Tray Deck Thickness, 3/8"-16 UNC-2B**
Insert abbreviated Material name from p. 6.

NON-STANDARD HARDWARE ITEMS

ITEM NO.	ITEM DESCRIPTION	CAGED NUTS	893
893-MMMM 21	Nut, Caged, Mat'l, for 14 Ga Tray Deck Thickness, 3/8"-16 UNC-2B		
893-MMMM 31	Nut, Caged, Mat'l, for 12 Ga or 10 Ga Tray Deck Thickness, 3/8"-16 UNC-2B		
893-MMMM 41	Nut, Caged, Mat'l, for 7 Ga or 3/16"t Tray Deck Thickness, 3/8"-16 UNC-2B		



ITEM NO.	ITEM DESCRIPTION	MANWAY LOCK CLAMPS 2-WAY	979
979-MMMM 201	Clamp, Manway Lock 2-Way, Mat'l, 12 Ga, 3/16" Lip		
979-MMMM 204	Clamp, Manway Lock 2-Way, Mat'l, 12 Ga, 3/8" Lip		
979-MMMM 209	Clamp, Manway Lock 2-Way, Mat'l, 12 Ga, 1" Lip		
979-MMMM 215	Clamp, Manway Lock 2-Way, Mat'l, 12 Ga, 1-3/4" Lip		
979-MMMM 301	* Clamp, Manway Lock 2-Way, Mat'l, 10 Ga, 3/16" Lip		
979-MMMM 304	* Clamp, Manway Lock 2-Way, Mat'l, 10 Ga, 3/8" Lip		
979-MMMM 309	* Clamp, Manway Lock 2-Way, Mat'l, 10 Ga, 1" Lip		
979-MMMM 315	* Clamp, Manway Lock 2-Way, Mat'l, 10 Ga, 1-3/4" Lip		



**Available in C.S.
Other sizes available in lip lengths with 1/16" increments.
Manway Lock Clamps 2-Way have a square hole for use with a square Manway Lock Stud #950.*

METRIC HARDWARE ITEMS

Commonly used for Canada and European locations only.

- ↳ **891-MMMM 03**
Insert Material identification number from chart on p. 6.
- ↳ **Nut, Hex. Mat'l, M10 x 1.5-6H**
Insert abbreviated Material name from p. 6.

ITEM NO.	ITEM DESCRIPTION	HEX NUTS	891
891-MMMM 03	Nut, Hex. Mat'l, M10 x 1.5-6H		
891-MMMM 04	Nut, Hex. Mat'l, M12 x 1.75-6H		

Available in other diameters upon request.

ITEM NO.	ITEM DESCRIPTION	CAGED NUTS	893
893-MMMM 22	Nut, Caged, Mat'l, for 2mm Tray Deck Thickness, M10 x 1.5-6H		
893-MMMM 32	Nut, Caged, Mat'l, for 2.5 or 3.5mm Tray Deck Thickness, M10 x 1.5-6H		
893-MMMM 42	Nut, Caged, Mat'l, for 4.5 or 5.0mm Tray Deck Thickness, M10 x 1.5-6H		

ITEM NO.	ITEM DESCRIPTION	HEX HEAD NUTS	896
896-MMMM 1305	Bolt, Hex. Head, Mat'l, M10 x 1.5-6g 25mm LG		
896-MMMM 1307	Bolt, Hex. Head, Mat'l, M10 x 1.5-6g 35mm LG		
896-MMMM 1310	Bolt, Hex. Head, Mat'l, M10 x 1.5-6g 50mm LG		
896-MMMM 1407	Bolt, Hex. Head, Mat'l, M12 x 1.75-6g 35mm LG		
896-MMMM 1410	Bolt, Hex. Head, Mat'l, M12 x 1.75-6g 50mm LG		
896-MMMM 1413	Bolt, Hex. Head, Mat'l, M12 x 1.75-6g 65mm LG		

Available in other diameters and lengths upon request.

ITEM NO.	ITEM DESCRIPTION	CARRIAGE BOLT	881
881-MMMM 0810	Bolt, Carriage, Mat'l, M10 x 1.5-6g		

The last two digits of the part number represents the length of the Bolt in 5mm increments (10 x 5mm = 50mm).
Available in other diameters and lengths upon request.

ITEM NO.	ITEM DESCRIPTION	MANWAY LOCK CLAMPS #2 & 3	860
860-MMMM 4	Clamp, Manway Lock #3, Mat'l, 5mm t for M10 Stud		
860-MMMM 5	*Clamp, Manway Lock #2, Mat'l, 6mm t for M10 Stud		

*Available in C.S.

ITEM NO.	ITEM DESCRIPTION	MANWAY LOCK CLAMPS #20 & 65	861
861-MMMM 1	Clamp, Manway Lock #20, Mat'l, 5mm t for M10 Stud		
861-MMMM 2	Clamp, Manway Lock #65, Mat'l, 5mm t for M12 Stud		
861-MMMM 3	*Clamp, Manway Lock #20, Mat'l, 6mm t for M10 Stud		
861-MMMM 5	*Clamp, Manway Lock #65, Mat'l, 6mm t for M12 Stud		

*Available in C.S.

ITEM NO.	ITEM DESCRIPTION	MANWAY CLAMP	938
938-MMMM 02 MMMM	Clamp, Manway, Mat'l, M10 x 1.5-6H Nut, Mat'l		

- **386-MMMM 0**
Insert Material identification number from chart on p. 6.
- **Washer, Bent Manway, Mat'l, 2mm t**
Insert abbreviated Material name from p. 6.

METRIC HARDWARE ITEMS

Commonly used for Canada and European locations only.

ITEM NO.	ITEM DESCRIPTION	BENT MANWAY WASHERS	386
386-MMMM 0	Washer, Bent Manway, Mat'l, 2mm t		
386-MMMM 1	Washer, Bent Manway, Mat'l, 2.5mm t		
386-MMMM 2	Washer, Bent Manway, Mat'l, 3mm t		
386-MMMM 3	Washer, Bent Manway, Mat'l, 3.5mm t		
386-MMMM 4	Washer, Bent Manway, Mat'l, 4mm t		
386-MMMM 5	Washer, Bent Manway, Mat'l, 4.5mm t		
386-MMMM 6	Washer, Bent Manway, Mat'l, 5mm t		

ITEM NO.	ITEM DESCRIPTION	MANWAY LOCK STUDS #5, 7, 10 & 11	865
865-MMMM 21	Stud, Manway Lock #5M, Mat'l, M10 x 1.5-6g x 50mm LG		
865-MMMM 22	Stud, Manway Lock #7M, Mat'l, M10 x 1.5-6g x 65mm LG		
865-MMMM 42	*Stud, Manway Lock #10M, Mat'l, M12 x 1.75-6g x 65mm LG		
865-MMMM 43	Stud, Manway Lock #11M, Mat'l, M12 x 1.75-6g x 75mm LG		

*For use with Manway Lock Clamp #70 and Manway Pointer #75 (Replaced MWL stud #9M, Part No. 587).

ITEM NO.	ITEM DESCRIPTION	BOTTOM TRAY CLAMPS "Y"	902
902-MMMM 01	Clamp, Bottom Tray "Y", Mat'l, 13mm Hole, 3mm t		
902-MMMM 02	Clamp, Bottom Tray "Y", Mat'l, 13mm Hole, 3.5mm t		

Bottom Tray Clamp "Y" designed for use with 25mm maximum thickness supports.

ITEM NO.	ITEM DESCRIPTION	BOTTOM TRAY CLAMPS "YD" (MANWAY)	903
903-MMMM 01	Clamp, Bottom Tray "YD", for M10 "D" shape Manway Stud, Mat'l, 3mm t		
903-MMMM 02	Clamp, Bottom Tray "YD", for M10 "D" shape Manway Stud, Mat'l, 3.5mm t		

Note: Other material types available on request for all BTC's.
Bottom Tray Clamp "YD" designed for use with 25mm maximum thickness supports

METRIC HARDWARE ITEMS

Commonly used for Canada and European locations only.

- ↳ 932-MMMM 013 MMMM
Insert Material identification number from chart on p. 6.
- ↳ **Clamp, Bottom Tray "YB", w/ bolt, Mat'l, 3mm t, M10 x 1.5-6g x 50mm Bolt, Mat'l**
Insert abbreviated Material name from p. 6.

ITEM NO.	ITEM DESCRIPTION	BOTTOM TRAY CLAMPS "YB"	932
932-MMMM 013 MMMM	Clamp, Bottom Tray "YB", w/ bolt, Mat'l, 3mm t, M10 x 1.5-6g x 50mm Bolt, Mat'l		
932-MMMM 014 MMMM	Clamp, Bottom Tray "YB", w/ bolt, Mat'l, 3mm t, M10 x 1.5-6g x 65mm Bolt, Mat'l		
932-MMMM 018 MMMM	Clamp, Bottom Tray "YB", w/ bolt, Mat'l, 3mm t, M10 x 1.5-6g x 75mm Bolt, Mat'l		
932-MMMM 023 MMMM	Clamp, Bottom Tray "YB", w/ bolt, Mat'l, 3.5mm t, M10 x 1.5-6g x 50mm Bolt, Mat'l		
932-MMMM 024 MMMM	Clamp, Bottom Tray "YB", w/ bolt, Mat'l, 3.5mm t, M10 x 1.5-6g x 65mm Bolt, Mat'l		
932-MMMM 028 MMMM	Clamp, Bottom Tray "YB", w/ bolt, Mat'l, 3.5mm t, M10 x 1.5-6g x 75mm Bolt, Mat'l		

Other material types and bolt lengths are available upon request.
Bottom Tray Clamp "YB" designed for use with 25mm maximum thickness supports.

ITEM NO.	ITEM DESCRIPTION	BOTTOM TRAY CLAMPS "YN"	946
946-MMMM 102 MMMM	Clamp, Bottom Tray "YN", w/ Nut, Mat'l, 3mm t, M10 x 1.5-6g Nut, Mat'l		
946-MMMM 202 MMMM	Clamp, Bottom Tray "YN", w/ Nut, Mat'l, 3.5mm t, M10 x 1.5-6g Nut, Mat'l		

Bottom Tray Clamp "YN" designed for use with 25mm maximum thickness supports.

ITEM NO.	ITEM DESCRIPTION	UNIVERSAL LEVER CLAMPS #1	315 331
315-MMMM 0	Clamp, Universal Lever #1, Mat'l, 2mm t, 11mm Hole		
315-MMMM 1	Clamp, Universal Lever #1, Mat'l, 2.5mm t, 11mm Hole		
315-MMMM 2	Clamp, Universal Lever #1, Mat'l, 3mm t, 11mm Hole		

ITEM #331
Single Lever Clamp #1 is available with welded bolt. Specify bolt diameter and length when ordering.
Our new Bottom Tray Clamp "Y" series replaces the old Single Lever Clamp #1.
902 BTC "Y" replaces the Single Lever Clamp #1 with open hole.
932 BTC "YB" replaces the Single Lever Clamp #1 with bolt.

ITEM NO.	ITEM DESCRIPTION	UNIVERSAL LEVER CLAMPS #3	317 333
317-MMMM	Clamp, Universal Lever #3, Mat'l, 2mm t, 11mm Hole		

ITEM #333
Single Lever Clamp #3 is available with welded bolt. Specify bolt diameter and length when ordering.
Our new Bottom Tray Clamp "Y" series replaces the old Single Lever Clamp #3.
902 BTC "Y" replaces the Single Lever Clamp #3 with open hole.
932 BTC "YB" replaces the Single Lever Clamp #3 with bolt.

ITEM NO.	ITEM DESCRIPTION	SINGLE LEVER CLAMPS	322
322-MMMM 014	Clamp, Single Lever, Mat'l, 3.5mm t, 8mm Tab length, M10 x 1.5-6g Tapped Hole		
322-MMMM 012	Clamp, Single Lever, Mat'l, 3.5mm t, 8mm Tab length, 11mm Hole		
322-MMMM 134	Clamp, Single Lever, Mat'l, 2.5mm t, 14mm Tab length, M10 x 1.5-6g Tapped Hole		
322-MMMM 132	Clamp, Single Lever, Mat'l, 2.5mm t, 14mm Tab length, 11mm Hole		
322-MMMM 254	Clamp, Single Lever, Mat'l, 3mm t, 20mm Tab length, M10 x 1.5-6g Tapped Hole		
322-MMMM 252	Clamp, Single Lever, Mat'l, 3mm t, 20mm Tab length, 11mm Hole		

Single Lever Clamp is available with additional tab lengths and hole sizes upon request.
Our new Bottom Tray Clamp "Y" series replaces the old Single Lever Clamp.
902 BTC "Y" replaces the Single Lever Clamp with open hole.
946 BTC "YN" replaces the Single Lever Clamp with tapped hole.

- 909-MMMM 001
Insert Material identification number from chart on p. 6.
- Seal Plate #10, Mat'l, 2mm t, 76mm LG
Insert abbreviated Material name from p. 6.

METRIC HARDWARE ITEMS

Commonly used for Canada and European locations only.

ITEM NO.	ITEM DESCRIPTION	SEAL PLATES	909
909-MMMM 001	Seal Plate #10, Mat'l, 2mm t, 76mm LG		
909-MMMM 002	Seal Plate #10A, Mat'l, 2mm t, 89mm LG		
909-MMMM 003	Seal Plate #10B, Mat'l, 2mm t, 102mm LG		
909-MMMM 004	Seal Plate #10C, Mat'l, 2mm t, 115mm LG		
909-MMMM 005	Seal Plate #10D, Mat'l, 2mm t, 127mm LG		
909-MMMM 000	Seal Plate #10X2, Mat'l, 2mm t, 51mm LG		
909-MMMM 006	Seal Plate, Mat'l, 2mm t, 64mm LG		
909-MMMM 007	Seal Plate, Mat'l, 2mm t, 152mm LG		
909-MMMM 008	Seal Plate, Mat'l, 2mm t, 140mm LG		



Seal Plates supplied in C.S. are 3.5mm t., the last three digits of the item no. is different for example, 201 instead of 001 for seal plate #10, 202 instead of 002 for seal plate #10A.

909 Replaced Item #848

ITEM NO.	ITEM DESCRIPTION	DOMED WASHERS	802
802-MMMM 101	Washer, Domed, Mat'l, 2mm t, 11mm id x 38mm od		
802-MMMM 301	*Washer, Domed, Mat'l, 3.5mm t, 11mm id x 38mm od		
802-MMMM 102	Washer, Domed, Mat'l, 2mm t, 11mm id x 44mm od		
802-MMMM 302	*Washer, Domed, Mat'l, 3.5mm t, 11mm id x 44mm od		
802-MMMM 103	Washer, Domed, Mat'l, 2mm t, 11mm id x 50mm od		
802-MMMM 303	*Washer, Domed, Mat'l, 3.5mm t, 11mm id x 50mm od		
802-MMMM 111	Washer, Domed, Mat'l, 2mm t, 14mm id x 38mm od		



*Available in C.S.

ITEM NO.	ITEM DESCRIPTION	FRICTIONAL WASHERS	800
800-MMMM 010801	Washer, Frictional, Mat'l, 2mm t, 11mm id x 25mm od		
800-MMMM 030801	*Washer, Frictional, Mat'l, 3.5mm t, 11mm id x 25mm od		
800-MMMM 020802	Washer, Frictional, Mat'l, 2.5mm t, 14mm id x 25mm od		
800-MMMM 030802	*Washer, Frictional, Mat'l, 3.5mm t, 14mm id x 25mm od		



Available in other diameters and thicknesses upon request.

*Available in C.S.

ITEM NO.	ITEM DESCRIPTION	HOOK BOLT #1	888
888-MMMM 24016	Hook Bolt #1, Mat'l, M10 x 1.5-6g x 200mm length (80mm thread length)		



Available in other bolt / thread lengths upon request.

ITEM NO.	ITEM DESCRIPTION	HOLDDOWN PLATES #1 & 2	887
887-MMMM 11	Plate, Holddown #1, Mat'l, 2mm t, 102mm wide		
887-MMMM 21	Plate, Holddown #1, Mat'l, 2.5mm t, 102mm wide		
887-MMMM 31	Plate, Holddown #1, Mat'l, 3.5mm t, 102mm wide		
887-MMMM 41	Plate, Holddown #1, Mat'l, 5mm t, 102mm wide		
887-MMMM 51	Plate, Holddown #1, Mat'l, 6mm t, 102mm wide		
887-MMMM 12	Plate, Holddown #2, Mat'l, 2mm t, 51mm wide		
887-MMMM 22	Plate, Holddown #2, Mat'l, 2.5mm t, 51mm wide		
887-MMMM 32	Plate, Holddown #2, Mat'l, 3.5mm t, 51mm wide		
887-MMMM 42	Plate, Holddown #2, Mat'l, 5mm t, 51mm wide		
887-MMMM 52	Plate, Holddown #2, Mat'l, 6mm t, 51mm wide		



ITEM NO.	ITEM DESCRIPTION	ANGLE HANGERS #161 THRU 163	916 917 918
916-MMMM 1	Hanger, Angle #161-A (75mm LG), Mat'l, 2.5mm t		
916-MMMM 2	Hanger, Angle #162-A (75mm LG), Mat'l, 3 or 3.5mm t		
916-MMMM 3	Hanger, Angle #163-A (75mm LG), Mat'l, 5mm t		
917-MMMM 1	Hanger, Angle #161-B (150mm LG), Mat'l, 2.5mm t		
917-MMMM 2	Hanger, Angle #162-B (150mm LG), Mat'l, 3 or 2.5mm t		
917-MMMM 3	Hanger, Angle #163-B (150mm LG), Mat'l, 5mm t		
918-MMMM 1125	Hanger, Angle #161-C (125mm LG), Mat'l, 2.5mm t		
918-MMMM 2130	Hanger, Angle #162-C (130mm LG), Mat'l, 3 or 2.5mm t		
918-MMMM 3135	Hanger, Angle #163-C (135mm LG), Mat'l, 5mm t		





KOCH-GLITSCH MAIN OFFICES

Koch-Glitsch, LP

4111 East 37th Street North
Wichita, Kansas 67220

tel: (1) 316-828-5110
fax: (1) 316-828-7985
info.wichita@kochglitsch.com

Emergency Hotlines

+1-888-562-4911 (mass transfer)
+1-316-207-7935 (mist elimination)

Koch-Glitsch Italia S.r.l.

Via Torri Bianche, 3A 20871
Vimercate MB Italy

tel: +39 039 6386010
fax: +39 039 6386011
info.vimercate@kochglitsch.com

Emergency Hotlines

+39-06-928-911
+44-1782-744561

Koch Engineered Solutions Singapore Pte. Ltd.

260 Orchard Road, #11-01/09
The Heeren
SINGAPORE 238855

tel: +65-6831-6500
fax: +65-6835-2031
info.singapore@kochglitsch.com

Emergency Hotlines

+65-6831-6500

For a complete list of our offices and facilities, visit koch-glitsch.com.

Trademarks

The following registered trademarks are owned by Koch-Glitsch, LP in the United States and may be registered in other jurisdictions: AHOP® Automated Hardware Ordering Program, BALLAST® tray, FLEXITRAY® tray, FLEXILOCK® tray construction, HORIZON® technology, KOCH-GLITSCH, "K" KOCH-GLITSCH, MINIVALVE® tray, OMNI-FIT® technology, PROVALVE® tray, SUPERFLUX® tray, SUPERFRAC® tray, and ULTRA-FRAC® tray. The following trademarks are owned by Koch-Glitsch, LP in the United States and may be registered in other jurisdictions: YOU CAN RELY ON US. All other trademarks, service marks, or registered trademarks that appear in this document are the trademarks or service marks of their respective owners.

For related trademark information, www.koch-glitsch.com/legal-notice/trademarks.

Patents

The following technologies are protected by one or more patents in the USA; other foreign patents may be relevant: FLEXILOCK® tray construction (US6592106), OMNI-FIT® technology (US6736378, US7055810, US7125005), PROVALVE® tray (US5762834), SUPERFLUX® tray (US5895608), SUPERFRAC® tray (US5762668, US5895608, US5632935), and ULTRA-FRAC® tray (US8500105, US8191870).

Legal Notice: The information contained in this bulletin is believed to be accurate and reliable, but is not to be construed as implying any warranty or guarantee of performance. Bulletin HWR-01. Printed in USA. © 2025. Koch-Glitsch, LP. All rights reserved.