

TAIL GAS THERMAL OXIDIZER

SUCCESSFUL LONG-TERM PERFORMANCE CASE STUDY

SITUATION

A German refinery asked us to replace their conventional tail gas thermal oxidizer. The existing equipment, which did not provide any energy recovery, had been in operation more than 40 years and the client needed a more advanced, engineered solution.

SOLUTION

The refinery wished to reduce CO₂ emissions and minimize fuel gas consumption in order to decrease operating expenses. While other inquiries made by the refinery failed to produce a viable solution, we proposed a recuperative thermal oxidizer system that would meet all the requirements. Engineers at the refinery, however, worried that the heat exchanger would corrode and need replaced in a short amount of time. In order to solve the issue, John Zink developed a specialized system design with materials highly resistant to corrosion.

RESULTS

The John Zink system has been operating successfully for more than 15 years. Other than routine maintenance work, there have been no major shutdowns. Corrosion concerns were addressed with the specialized material and no issues have been reported. No major equipment—including the burner, combustion chamber, or heat exchanger—has needed replacement. Performance has exceeded expectations. The new system is meeting the most stringent emissions regulations in H₂S, COS, CS₂, CO and NO_x. CO₂ emissions have decreased dramatically and operating expenses have been reduced by approximately 90%.

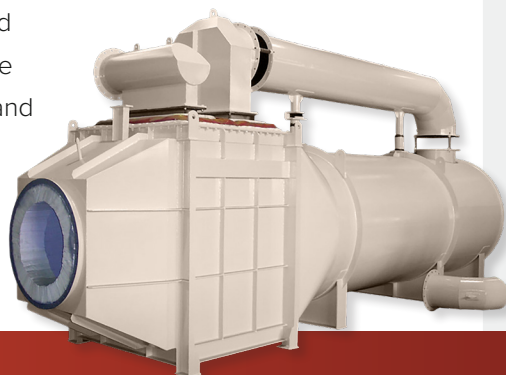

Performance At-A-Glance

The recuperative thermal oxidizer system has been operating successfully for more than 15 years.

- Operating expenses: reduced approximately 90%
- Fuel gas consumption: reduced by more than 70%
- Electrical consumption: reduced by more than 65%
- CO₂ emissions: reduced by around 60%
- No unplanned shutdowns
- No major equipment replacement since initial startup
- H₂S, COS, CS₂, CO and NO_x emissions regulations all being met

THE DESIGN

The recuperative thermal oxidizer system designed by John Zink engineers was a major upgrade for the refinery.

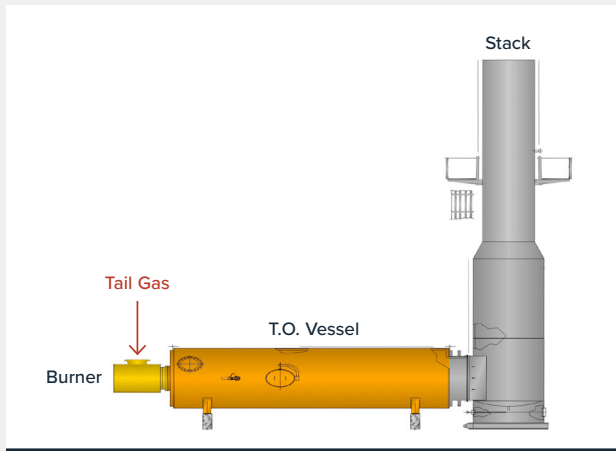

EXISTING Tail Gas TO System

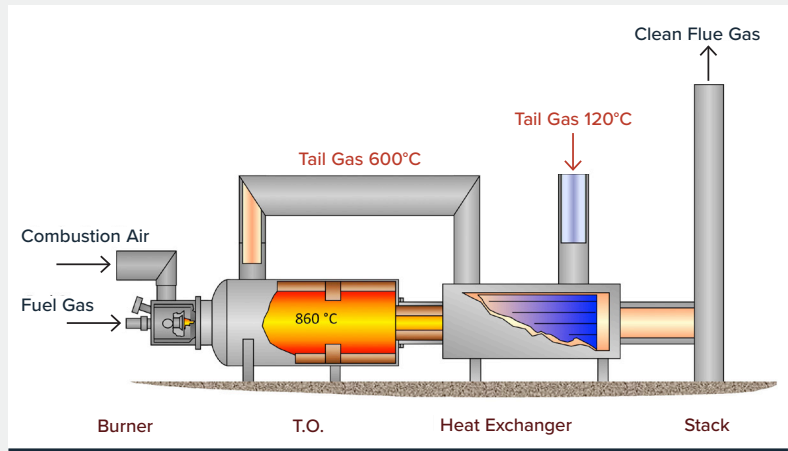

NEW Tail Gas TO System

Try Our Newest Innovation: TrīLo Technology

We've leveraged the experience gained from this long-term success and developed exclusive innovations to create a new generation of tail gas thermal oxidizers using TrīLo Technology. Compared to conventional thermal oxidizer performance, a TO engineered with TrīLo Technology delivers three important advantages:

1 Lower Fuel and Power Consumption

Operates efficiently, reducing fuel costs up to 40% without preheating the tail gas or combustion air.

2 Lower Operating Temperature

Meets emissions standards at the lowest known operating temperature in the market.

3 Lower NO_x, CO and CO₂ Emissions

Guaranteed lowest NO_x and CO emissions in the industry. Reduces carbon footprint by emitting less CO₂.

© 2024 John Zink, LLC. All Rights Reserved.

See how TrīLo Technology can work for you. Email trilo@johnzink.com today.

Global Headquarters // Tulsa, OK, USA // +1-918-234-1800 // To locate an office in your region, visit johnzink.com/contact.