

# PACKED TOWER

## INTERNALS

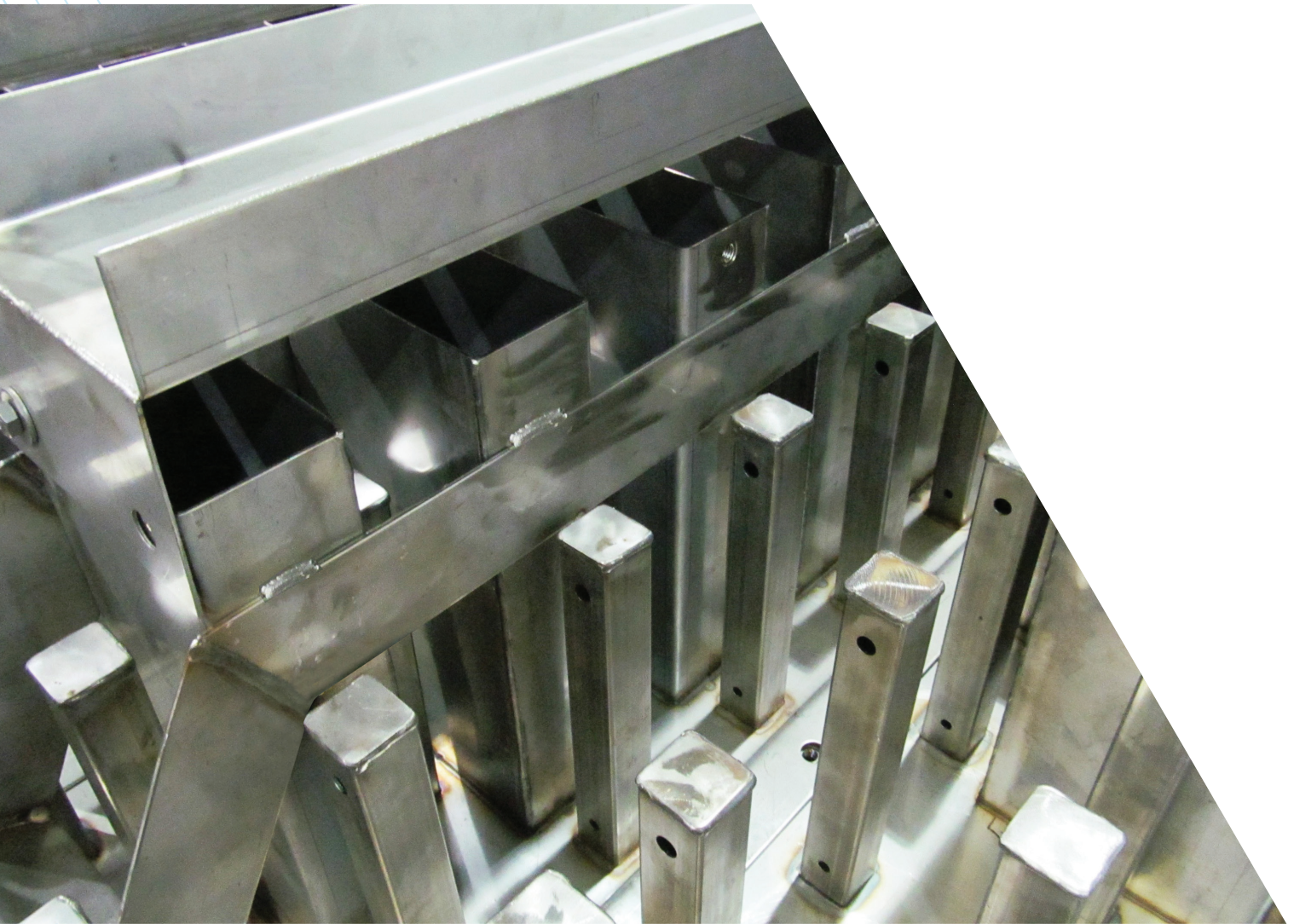

 **KOCH-GLITSCH™**

A KOCH ENGINEERED SOLUTIONS BUSINESS

# TABLE OF CONTENTS

Introduction.....	2
High Performance Liquid Distributors.....	3
Standard Liquid Distributors.....	8
Feed Devices.....	10
Liquid Collectors.....	15
Bed Limiters.....	17
Support Plates.....	18
Internals for Offshore Applications.....	19
Internals for Liquid-Liquid Extraction.....	20
Engineered Beams.....	22
Technical Guide .....	23
Construction Details.....	29
Other Tower Internals.....	30
Minimum Support Ring Widths .....	30
Index.....	31

## KOCH-GLITSCH PACKING & INTERNALS

Being fully aware of the importance of uniform liquid and vapor distribution as well as re-distribution of liquid, Koch-Glitsch engineers give careful attention to the selection and design of an equipment solution to meet customer specifications and to best handle any special process considerations, such as fouling or foaming. Koch-Glitsch offers a proven line of distributors and redistributors for a wide range of flow rates, physical properties, and turndown requirements. Our internals are available in a variety of styles and materials, including any formable, weldable sheet metal materials, such as carbon or stainless steel, nickel and copper alloys, aluminum, titanium, and zirconium; ceramic; graphite; and many plastics.

- ▼ For high performance packed towers, INTALOX® Packed Tower Systems technology treats the packing and associated internals as a system that works together to provide optimal performance. An INTALOX Packed Tower Systems design combines well-matched high performance packing and state-of-the-art liquid and vapor distribution to create predictable and reliable separation column performance. Packing supports, hold-downs, liquid collectors, and other internals are designed to accommodate the higher capacities of high performance packing. For a further discussion of the importance of liquid and vapor distribution and the circumstances in which INTALOX Packed Tower Systems technology should be applied, please refer to the Technical Guide starting on page 23.
- ▼ For towers in less demanding services, Koch-Glitsch offers a wide range of standard-style internals that provide efficient packed towers that perform as designed.

Tackling the industry’s challenge for larger and larger columns, Koch-Glitsch makes use of its extensive experience to break new records for column diameter. Innovative supports developed by Koch-Glitsch enhance process performance and reduce equipment installation time.

Sectionalized beam and pinned truss are two of the latest patented mechanical designs (see page 22). The lighter individual components resulting from these innovative designs are safer to handle and easier to install. Each of these support designs provides increased mechanical strength and minimizes or eliminates the need for field welding in revamps of existing columns. These characteristics are confirmed through rigorous mechanical analysis for each project.

For tower internals that are not described in detail in the brochure, please refer to Other Tower Internals on page 30. The Index on page 31 contains a detailed list of the equipment described in this brochure.

## HIGH PERFORMANCE LIQUID DISTRIBUTORS

Koch-Glitsch developed the INTALOX® high performance liquid distributors with attributes to maximize packed tower performance. To quantify distribution quality and performance, Koch-Glitsch created a distributor evaluation system that rates distribution uniformity as a percentage. 100% indicates ideal uniform distribution. A low percentage rating indicates a high variation of liquid flow over the cross-sectional area of the tower. In addition, the distributor must provide a sufficient gas passage area to avoid a high pressure drop or liquid entrainment. The significance of the Koch-Glitsch distribution quality rating system is the accurate prediction of tower performance.

### Model 106/107 Pan Distributor

- ▼ Metering device: Deck level orifice
- ▼ Liquid rates: 2-80 gpm/ft<sup>2</sup> [5-195 m<sup>3</sup>/h/m<sup>2</sup>]
- ▼ Tower diameter: 0.5-3 ft [150-900 mm]
- ▼ Support features: Wall clips or body flange mount
- ▼ Redistribution: Vapor riser covers and wall wiper (Model 107)
- ▼ Standard design features
  - 2:1 turndown ratio
  - Glass fiber gaskets
  - Small rectangular risers maintain good vapor distribution
  - Additional vapor passage between distributor and tower wall
  - Good liquid cross-flow
- ▼ Optional design features
  - Drip tubes for increased operating range and fouling resistance
  - Guide tubes below deck separate liquid from high velocity vapor near risers
  - Anti-migration device at base of vapor riser replaces separate bed limiter
  - Alternate gasket material

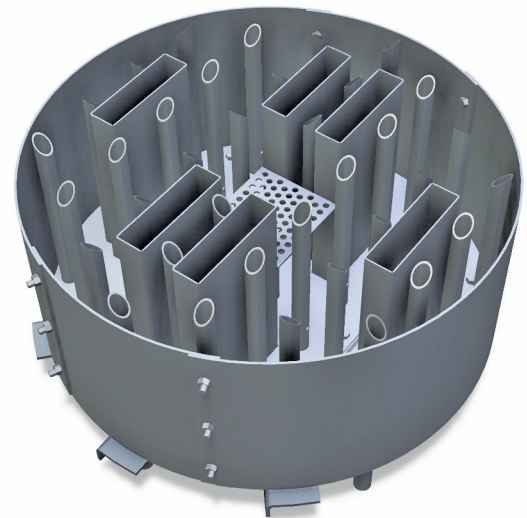

### Model 116/117 Deck Distributor

- ▼ Metering device: Deck level orifice
- ▼ Liquid rates: 4-80 gpm/ft<sup>2</sup> [10-195 m<sup>3</sup>/h/m<sup>2</sup>]
- ▼ Tower diameter: 1.5-20 ft [450-6100 mm]
- ▼ Support features: Full circumference tower ledge
- ▼ Redistribution: Vapor riser covers (Model 117)
- ▼ Standard features
  - 2:1 turndown ratio
  - Glass fiber gaskets
  - Small rectangular risers maintain good vapor distribution
  - Good liquid cross-flow
- ▼ Optional features
  - Drip tubes for increased operating range and fouling resistance
  - Guide tubes below deck segregate liquid from high velocity vapor near risers
  - Anti-migration device at base of vapor riser replaces separate bed limiter
  - Alternate gasket material

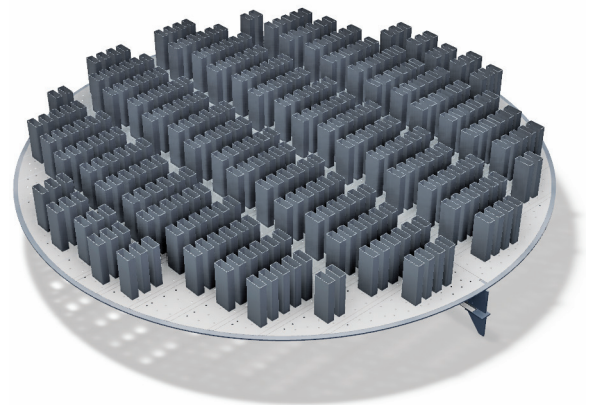

## Model 136/137 Channel Distributor

---

- ▼ Metering device: Channel wall orifices with guide tubes
- ▼ Liquid rates: 0.3-15 gpm/ft<sup>2</sup> [0.7-37 m<sup>3</sup>/h/m<sup>2</sup>]
- ▼ Tower diameter: > 3 ft [900 mm]
- ▼ Support features: Full circumference ring or beams
- ▼ Redistribution: Covers between channels and wall wiper (Model 137)
- ▼ Standard features
  - Center channel for structural support and reduced height requirement
  - 2:1 turndown ratio
  - Glass fiber gaskets
  - Guide tubes segregate liquid from high velocity vapor between channels
  - Elevated metering orifices provide fouling resistance
- ▼ Optional features
  - Multi-level orifices for increased operating range
  - Second level of covers provide liquid cross-mixing
  - Multiple center channels for higher
  - Alternate gasket material

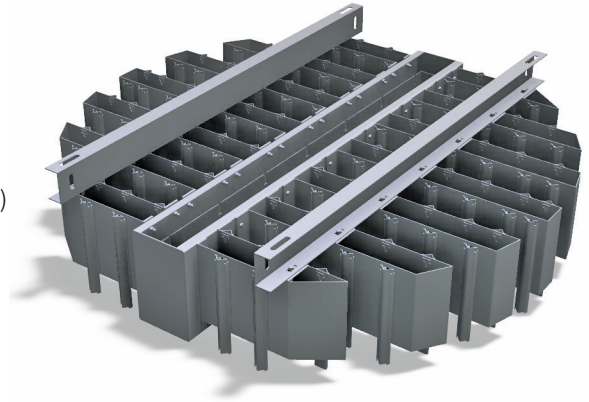

## Model 141 Tubular Distributor

---

- ▼ Metering device: Orifices in lateral tubes
- ▼ Liquid rates: 0.3-8 gpm/ft<sup>2</sup> [0.7-20 m<sup>3</sup>/h/m<sup>2</sup>]
- ▼ Tower diameter: > 0.5-10 ft [150-3000 mm]
- ▼ Support features: Beams or on packing with special support grid
- ▼ Redistribution: Separate liquid collector
- ▼ Standard features
  - High drip point density provides good distribution to wire gauze structured packing
  - 2:1 turndown ratio
  - For use with clean services only
- ▼ Optional features
  - Additional receiver height allows increased operating range

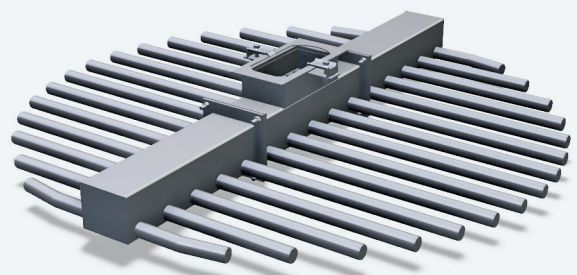

## Model 156 Trough Distributor

- ▼ Metering device: Trough wall metering orifices with enhanced baffles
- ▼ Liquid rates: 0.1-15 gpm/ft<sup>2</sup> [0.25-37 m<sup>3</sup>/h/m<sup>2</sup>]
- ▼ Tower diameter: > 3 ft [900 mm]
- ▼ Support features: Directly on packing or beams
- ▼ Redistribution: Separate liquid collector
- ▼ Standard features
  - For use with structured packing only
  - 2:1 turndown ratio
  - Enhanced baffle includes surface treatment for liquid spreading and serrated bottom to prevent liquid tracking
  - Baffle alignment ensures complete wetting of bottom of first layer
  - Elevated metering orifices provide fouling resistance
  - Overflow protection
  - Reduced drip point density allows for larger orifices
  - Secondary baffle shields liquid from high velocity vapor between troughs
- ▼ Optional features
  - Multi-level orifices for increased operating range
  - Multiple parting boxes for higher liquid capacity
  - Pre-distribution channels provide velocity reduction for higher liquid capacity

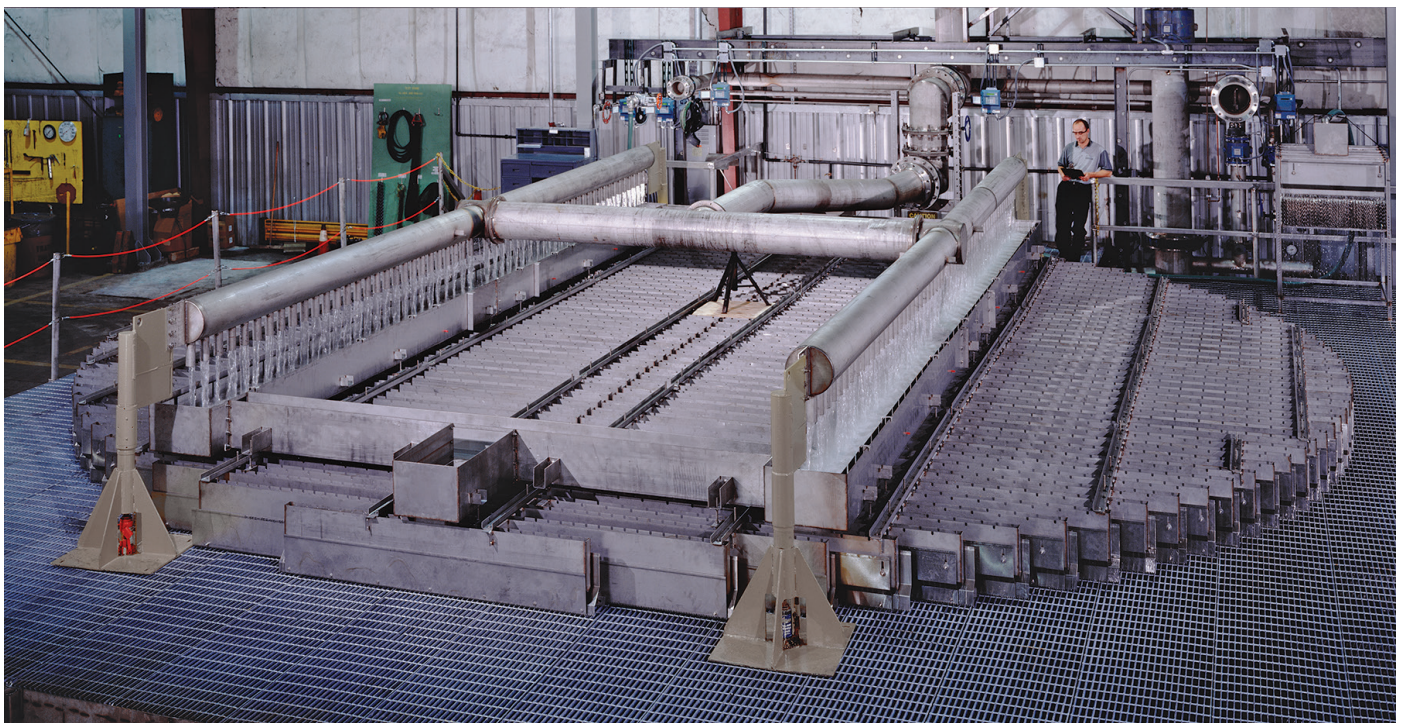
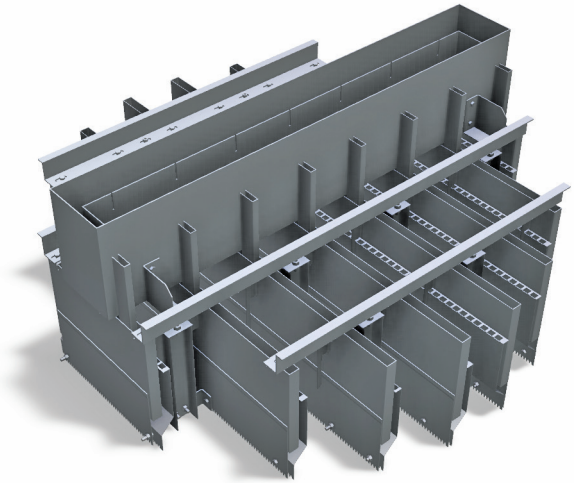

KOCH-GLITSCH'S COMMERCIAL-SCALE DISTRIBUTOR TEST FACILITY, WICHITA, KANSAS, USA

## Model 166 Dual Trough Low Flow Distributor

- ▼ Metering device: Trough wall orifices with enhanced baffles
- ▼ Liquid rates: 0.05-5 gpm/ft<sup>2</sup> [0.12-12 m<sup>3</sup>/h/m<sup>2</sup>]
- ▼ Tower diameter: > 3 ft [900 mm]
- ▼ Support features: Directly on packing or beams
- ▼ Redistribution: Separate liquid collector
- ▼ Standard features
  - For use with structured packing only
  - 2:1 turndown ratio
  - Secondary trough spreads liquid and feeds enhanced baffle
  - Enhanced baffle includes surface treatment for liquid spreading and serrated bottom to prevent liquid tracking
  - Baffle alignment ensures complete wetting at bottom of first layer
  - Elevated metering orifices provide fouling resistance
  - Overflow protection
  - Reduced drip point density allows for larger orifices
  - Secondary baffle shields liquid from high velocity vapor between troughs
- ▼ Optional features
  - Multi-level orifices for increased operating range
  - Multiple parting boxes for higher liquid capacity
  - Pre-distribution channel

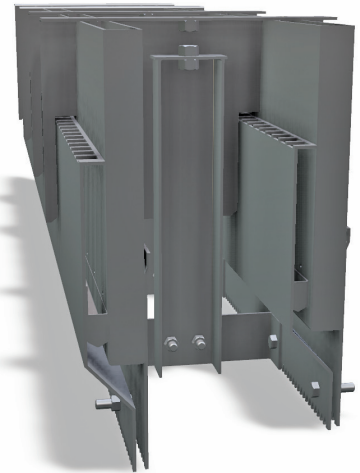

KOCH INDUSTRIES CORPORATE HEADQUARTERS, WICHITA, KANSAS, USA. ALSO LOCATION OF KOCH-GLITSCH WORLDWIDE HEADQUARTERS.

## Model 186 Trough Distributor

- ▼ Metering device: Trough wall orifices with guide tubes
- ▼ Liquid rates: 0.1-25 gpm/ft<sup>2</sup> [0.25-60 m<sup>3</sup>/h/m<sup>2</sup>]
- ▼ Tower diameter: > 3 ft [900 mm]
- ▼ Support features: Beams or on packing with special support grid
- ▼ Redistribution: Separate liquid collector
- ▼ Standard features
  - 2:1 turndown ratio
  - Guide tubes segregate liquid from high velocity vapor between troughs
  - Elevated metering orifices provide fouling resistance
  - Overflow protection
- ▼ Optional features
  - Multi-level orifices for increased operating range
  - Multiple parting boxes for higher liquid capacity
  - Pre-distribution channels provide velocity reduction for higher liquid capacity

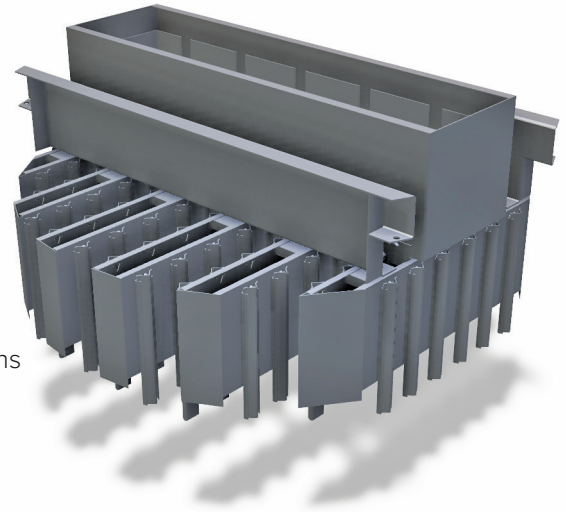

## Model 196 Packed Trough Very Low Flow Distributor

- ▼ Metering device: Trough wall orifices with packed secondary troughs
- ▼ Liquid rates: 0.03-5 gpm/ft<sup>2</sup> [0.07-12 m<sup>3</sup>/h/m<sup>2</sup>]
- ▼ Tower diameter: > 3 ft [900 mm]
- ▼ Support features: Beams or on packing with special support grid
- ▼ Redistribution: Separate liquid collector
- ▼ Standard features
  - For use with structured packing only
  - 2:1 turndown ratio
  - Secondary trough alignment ensures complete wetting at bottom of first layer
  - Elevated metering orifices provide fouling resistance
  - Overflow protection
  - Reduced drip point density allows for larger orifices
  - Low liquid entrainment
- ▼ Optional features
  - Multi-level orifices for increased operating range
  - Multiple parting boxes for higher liquid capacity
  - Pre-distribution channels provide velocity reduction for higher liquid capacity
  - Special design for liquid-liquid applications

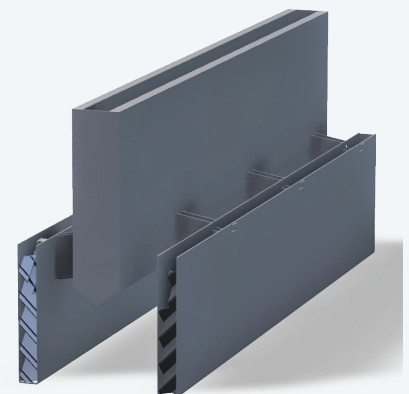
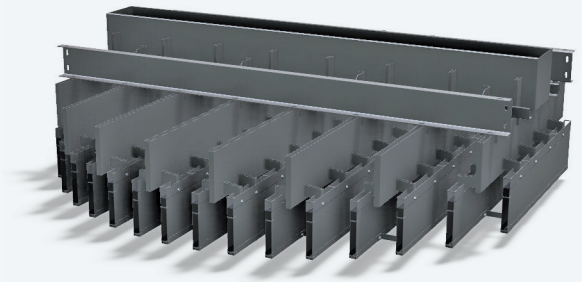

# STANDARD LIQUID DISTRIBUTORS

Less demanding applications, such as heat transfer with large approach temperatures or absorption requiring only one or two transfer units, may not require the high level of distribution quality provided by INTALOX® liquid distributors. For these situations, standard liquid distributors can provide adequate performance at reduced cost. Drip point patterns, drip point density, and flow variation will not be to the exacting INTALOX Packed Tower Systems specifications; however, Koch-Glitsch engineers have decades of experience applying these distributors in a wide variety of services.

## Model 916/917 Deck Distributor

---

- ▼ Metering device: Deck level metering orifice
- ▼ Liquid rates: 1-50 gpm/ft<sup>2</sup> [2.4-122 m<sup>3</sup>/h/m<sup>2</sup>]
- ▼ Tower diameter: 1.5-20 ft [450-6100 mm]
- ▼ Support feature: Full circumference tower ledge
- ▼ Redistribution: Vapor riser covers (Model 917)
- ▼ Standard features
  - 2.5:1 turndown ratio
  - Glass fiber gaskets
  - Long rectangular risers
- ▼ Optional features
  - Anti-migration device at base of vapor riser replaces separate bed limiter
  - Alternate gasket material

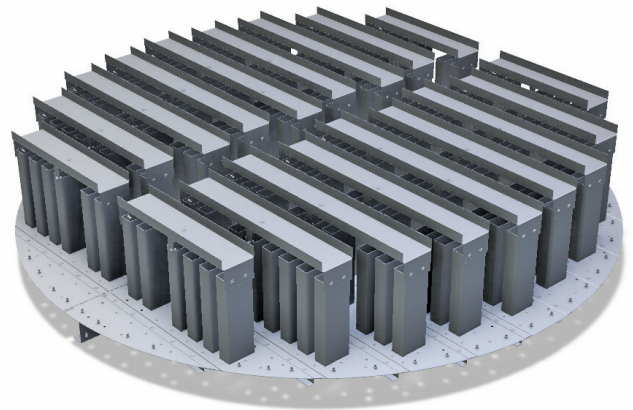

## Model 941 Pipe Distributor

---

- ▼ Metering device: Metering orifice in pipe laterals
- ▼ Liquid rates: 1.5-10 gpm/ft<sup>2</sup> [3.7-24 m<sup>3</sup>/h/m<sup>2</sup>]
- ▼ Tower diameter: > 1.5 ft [450 mm]
- ▼ Support features: Supported by wall clips or beams
- ▼ Redistribution: Separate liquid collector between beds
- ▼ Standard features
  - 2.5:1 turndown ratio
  - Requires little tower elevation
  - Very high open area
  - Flange connections
  - PTFE gaskets
- ▼ Optional features
  - Alternate gasket material
  - Vertical feed header on tower centerline

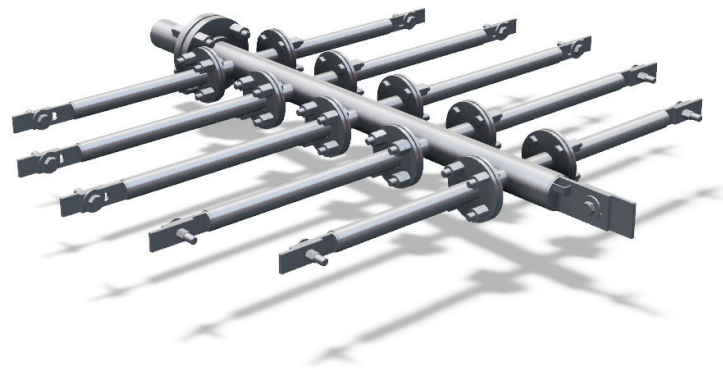



## Model 943 Spray Nozzle Distributor

- ▼ Metering device: Spray nozzle
- ▼ Liquid rates: 0.2-50 gpm/ft<sup>2</sup> [0.5-122 m<sup>3</sup>/h/m<sup>2</sup>]
- ▼ Tower diameter: No restrictions
- ▼ Support features: Wall clips or beams
- ▼ Redistribution: None
- ▼ Standard features
  - 2:1 turndown ratio
  - PTFE gaskets
  - Full cone spray nozzles with 90° or 120° cone angle
  - Maximum free passage nozzles for fouling resistance
  - Pressurized feed
- ▼ Optional features
  - Alternate gasket material
  - Special designs to eliminate liquid stagnation and coking
  - 200% coverage to ensure complete wetting of the packed bed

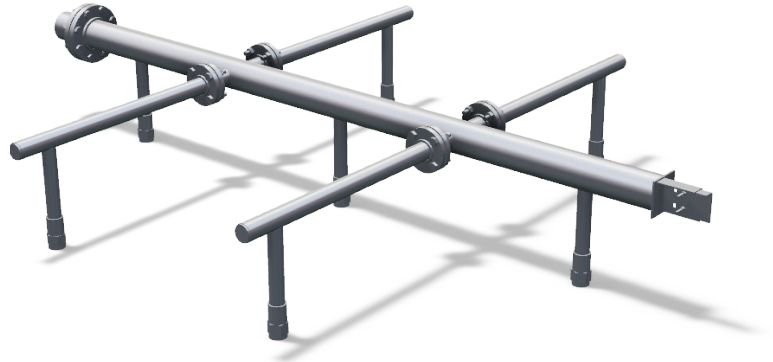

## Model 985 Trough Distributor

- ▼ Metering device: Trough wall v-notches
- ▼ Liquid rates: 2-40 gpm/ft<sup>2</sup> [5-98 m<sup>3</sup>/h/m<sup>2</sup>]
- ▼ Tower diameter: > 3 ft [900 mm]
- ▼ Support features: Full circumference tower ledge or beams
- ▼ Redistribution: Separate liquid collector
- ▼ Standard features
  - 2.5:1 turndown ratio
  - Excellent fouling resistance
- ▼ Optional features
  - Distribution notch shape
  - Guide channels for better distribution quality
  - Slotted weirs for lower flow, less fouling services
  - Multiple parting boxes for higher liquid capacity

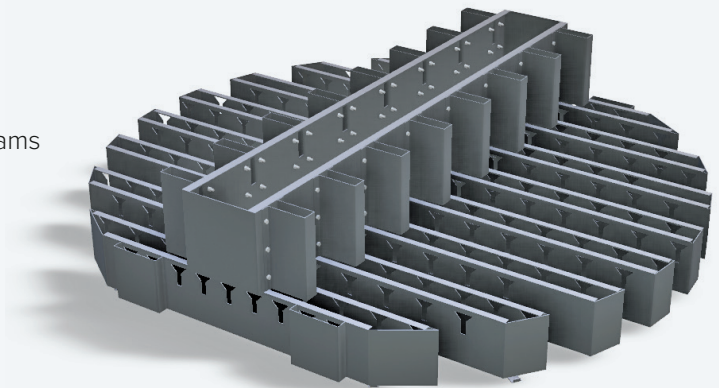

## FEED DEVICES

Optimal tower performance requires the proper handling of liquid and vapor entering the column. The types of feeds or inlets into a column are generally classified into four major categories: liquid only, mixed liquid/vapor and flashing, vapor only, and reboiler returns. Koch-Glitsch offers a variety of devices designed to handle each of these situations. For additional discussion of the feed categories, refer to page 28 in the Technical Guide.

### Model 719 Feed Pipe

---

- ▼ Tower diameter: No restriction
- ▼ Support features: Wall clips or beams
- ▼ Standard features
  - 2.5:1 turndown ratio
  - PTFE gaskets
  - Single straight header
  - Liquid phase only
- ▼ Optional features
  - Alternate gasket material

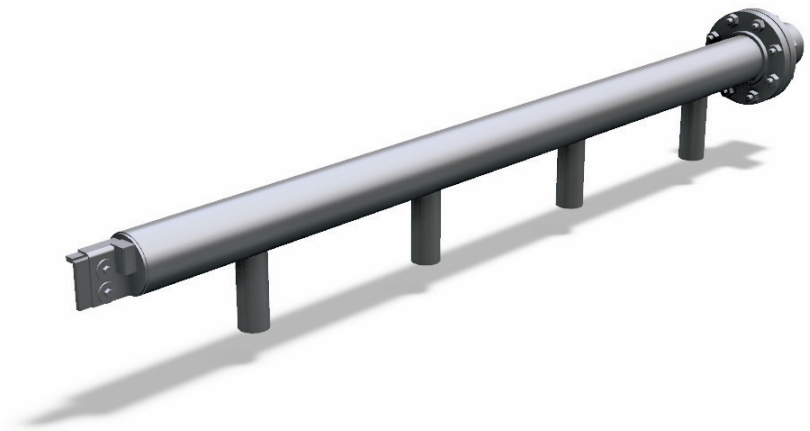

### Model 119 Feed Pipe

---

- ▼ Tower diameter: No restriction
- ▼ Support features: Wall clips or beams
- ▼ Standard features
  - 2:1 turndown ratio
  - PTFE gaskets
  - T or H configuration for higher rates
  - Liquid phase only
  - Restriction orifices maintain equalized flow to each branch
  - Guide pipes prevent horizontal liquid velocity vector
- ▼ Optional features
  - Alternate gasket material
  - Diffuser plates below guide pipes to dissipate liquid kinetic energy

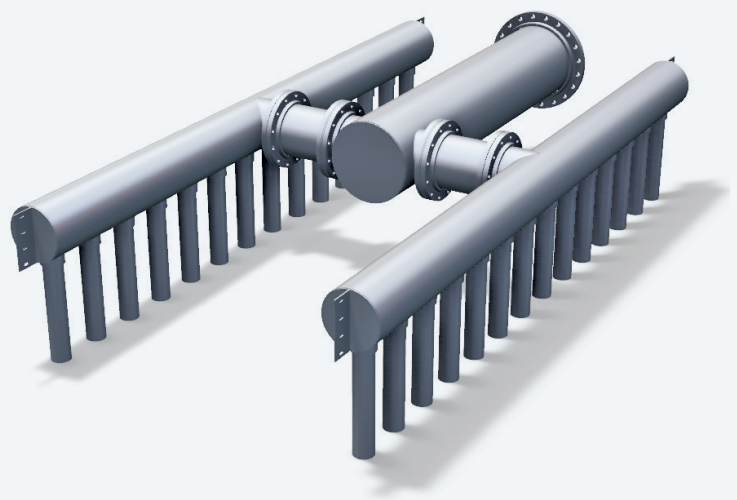

## Model 745 Flashing Feed Pipe

---

- ▼ Tower diameter: > 3 ft [900 mm] tower diameter
- ▼ Support features: Wall clips or beams
- ▼ Standard features
  - PTFE gaskets
  - Single straight header
  - Liquid and vapor phase
  - Feed impinges on the inside of the flash box, promoting disengagement of the liquid and vapor phases
  - Less column height required compared to flash gallery
- ▼ Optional features
  - Alternate gasket material
  - Vapor hood
  - Available in T and H configurations



## Model 705 Flashing Feed Chamber

---

- ▼ Tower diameter: 1-4 ft [300-1200 mm] tower diameter
- ▼ Support features: Wall clips
- ▼ Standard features
  - PTFE gaskets
  - Liquid and vapor phase
  - Centrifugal force disengages the liquid and vapor phases
  - Less column height required compared to flash gallery
- ▼ Optional features
  - Alternate gasket material
  - Additional chambers for larger tower diameters

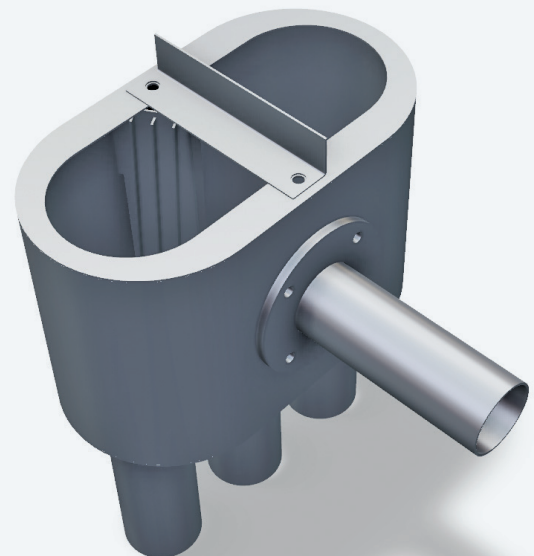

## Model 788 V-Baffle Inlet Diffuser

---

- ▼ Tower diameter: > 2.5 ft [760 mm]
- ▼ Support features: Welded to vessel wall
- ▼ Standard features
  - Liquid/vapor phases or vapor only
  - Reduces inlet stream energy
  - Can be used in place of more complex vapor distribution devices provided the ratio of inlet velocity head to packing pressure drop is low
  - Very effective low pressure drop phase separator
- ▼ Optional features
  - Anti-swirl baffles
  - Erosion allowance

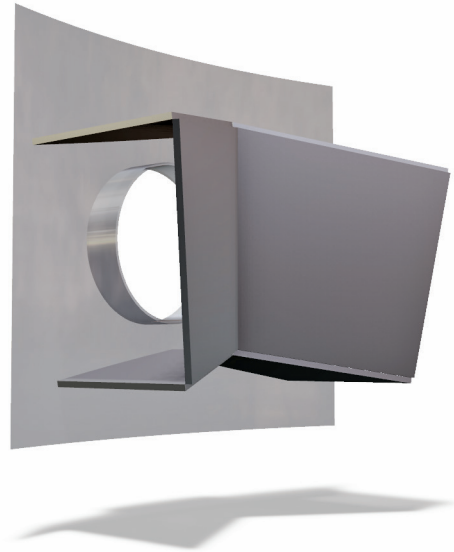

## Model 755 Flashing Feed Gallery

---

- ▼ Tower diameter: > 3 ft [900 mm] tower diameter
- ▼ Support features: Full circumference tower ledge
- ▼ Standard features
  - Glass fiber gaskets
  - Inlet diffuser
  - Liquid/vapor or flashing feeds
  - Feed impinges tangentially on vessel wall, promoting disengagement of the liquid and vapor phases
  - Metering orifices direct liquid to distributor below
  - Requires increased column height for aerated fluids, such as those found in high pressure fractionators
- ▼ Optional features
  - Alternate gasket material
  - Center sump to feed distributor parting box
  - Fitting with vanes for collection of liquid from above

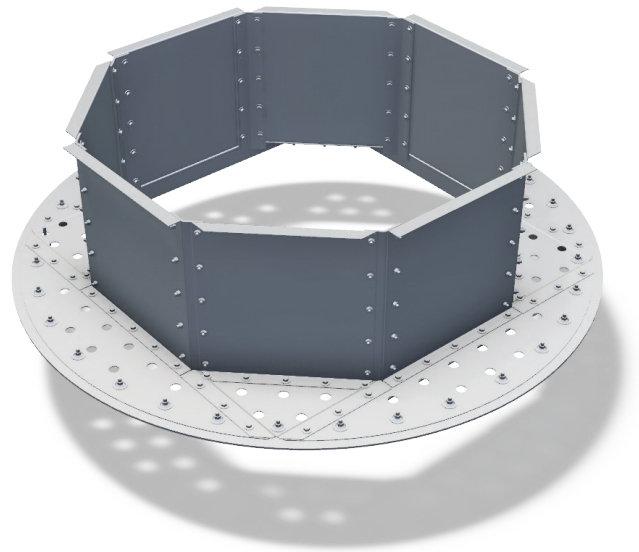

## Model 758 Enhanced Vapor Horn

- ▼ Tower diameter: > 6 ft [1800 mm]
- ▼ Support features: Welded to vessel wall
- ▼ Standard features
  - Suitable for vapor only, mixed liquid/vapor, or flashing feeds
  - Partial or full circumference open bottom horn
  - Centrifugal action imparted to feed directs entrained liquid to vessel wall
  - Specifically positioned turning vanes break the high feed inlet velocity for improved vapor distribution and de-entrainment
  - Anti-swirl baffles positioned on the outside of the horn eliminate the cyclonic motion of the vapor
  - Designed to ensure adequate gas oil quality and yield, maximum column capacity, and proper wash bed performance when used for crude vacuum tower feed
  - Radial or tangential inlet configuration
- ▼ Optional features
  - Multiple feed inlets
  - Heavy-duty design for increased uplift protection
  - Wear plates
  - CFD analysis (including entire flash zone of crude towers)

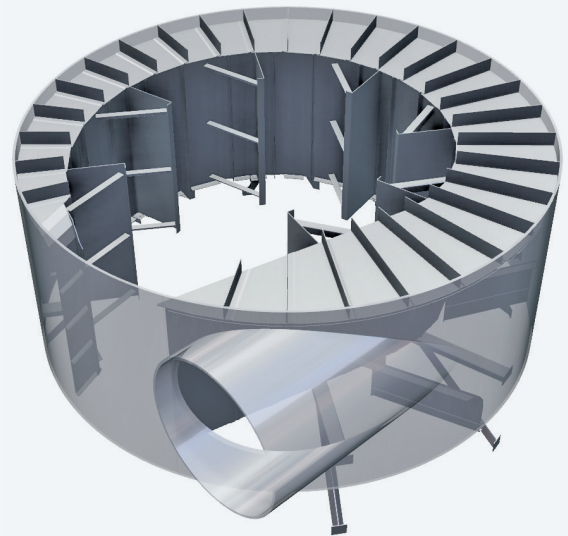

## Model 746 Pipe Vapor Distributor

- ▼ Tower diameter: > 1.5 ft [450 mm] tower diameter
- ▼ Support features: Wall clips or beams
- ▼ Standard features
  - 4:1 turndown
  - PTFE gaskets
  - Vapor phase only
  - Pressure drop across metering orifices provides uniform distribution across tower area
  - Provides good vapor distribution for feeds between packed beds where vapor composition may be different
  - Requires less column height compared to a deck vapor distributor

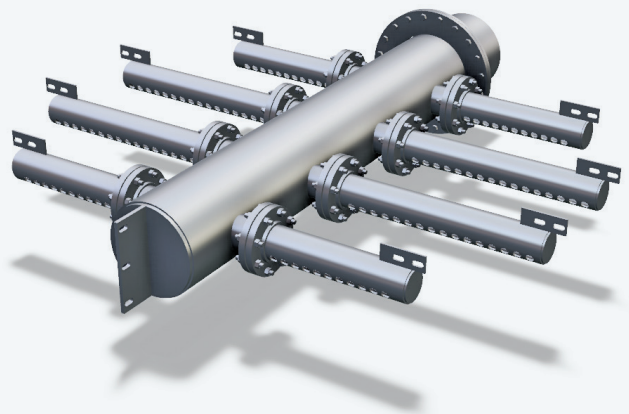

## Model 768 YORK-EVENFLOW Vane Inlet Device

---

- ▼ Tower diameter: > 6 ft [1800 mm]
- ▼ Support features: Beams or welded to vessel wall
- ▼ Standard features
  - 4:1 turndown
  - Suitable for high energy vapor inlet streams entering through a radial inlet
  - Baffles used in conjunction with tapered inlet provide vapor distribution with minimal pressure drop
  - Curved baffle plates partition vapor stream into multiplesmall segments, reducing the velocity and directing the vapor horizontally across the column area
- ▼ Optional features
  - Field welded construction
  - CFD analysis

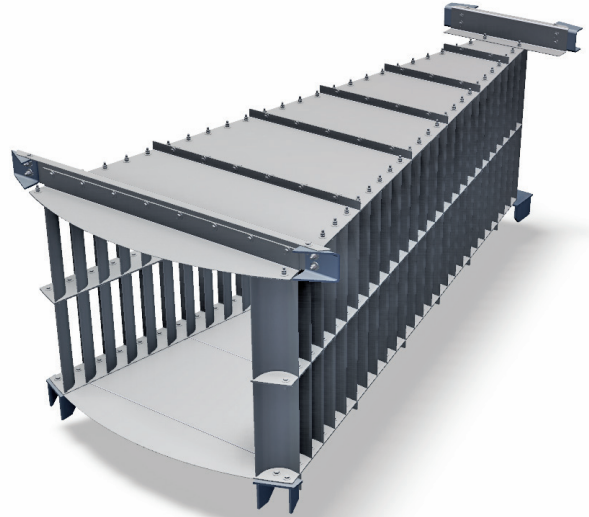

## Model 716 Deck Vapor Distributor

---

- ▼ Tower diameter: > 2.5 ft [450 mm]
- ▼ Support features: Full circumference tower ledge
- ▼ Standard features
  - 4:1 turndown
  - Glass fiber gaskets
  - Correct poor vapor distribution below a packed bed
  - Restrictor plates at bottom of vapor risers provide sufficient pressure drop to distribute vapor evenly across tower area
  - Sufficient number of vapor risers to ensure good distribution
  - Side or center sump for liquid flow
- ▼ Optional features
  - Field welded construction
  - Pipe downcomers
  - Heavy-duty design for increased uplift resistance

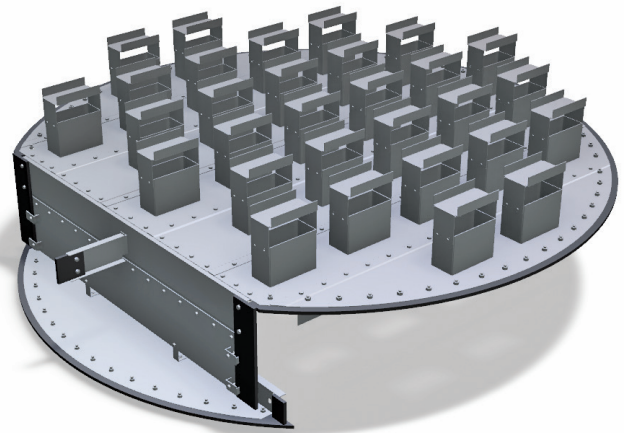

## LIQUID COLLECTORS

Liquid collection between packed beds is frequently required. The reasons for using liquid collectors are varied; therefore, the design is tailored to every application. Benefits of a separate collector include improvement in cross mixing of liquid before redistribution and mixing of feed streams with the internal column liquid. For examples of situations where liquid collection might be needed, refer to Liquid Collectors on page 26 in the Technical Guide.

### Model 611 Deck Liquid Collector

- ▼ Tower diameter: No restriction
- ▼ Support features: Full circumference tower ledge or body flange mounting
- ▼ Standard features
  - Glass fiber gaskets
  - Sufficient vapor risers to maintain good vapor distribution
  - Single or multiple sumps
  - Center or side sump location
  - Total or partial draw
- ▼ Optional features
  - Alternate gasket material
  - Field welded construction
  - Pipe downcomers

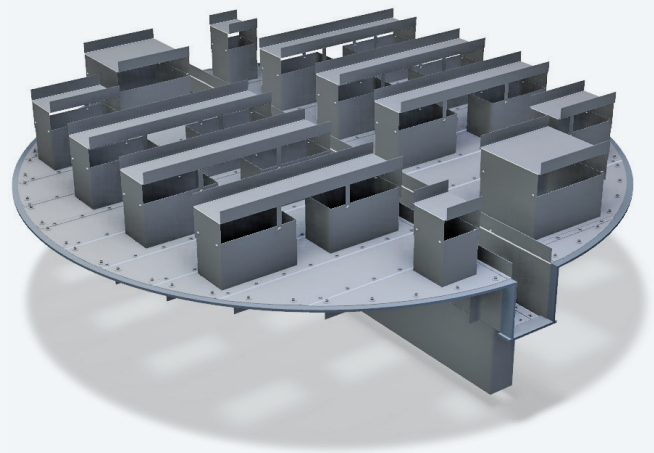

### Model 621 Trough Liquid Collector

- ▼ Tower diameter: > 3.5 ft [1100 mm]
- ▼ Support features: Full circumference tower ledge
- ▼ Standard features
  - Glass fiber gaskets
  - Sufficient vapor risers to maintain good vapor distribution
  - Single or multiple sumps
  - Center sump location
  - Thermal expansion allowance
  - Wall wiper to direct liquid to troughs
  - Total or partial draw
- ▼ Optional features
  - Alternate gasket material
  - Pipe downcomers

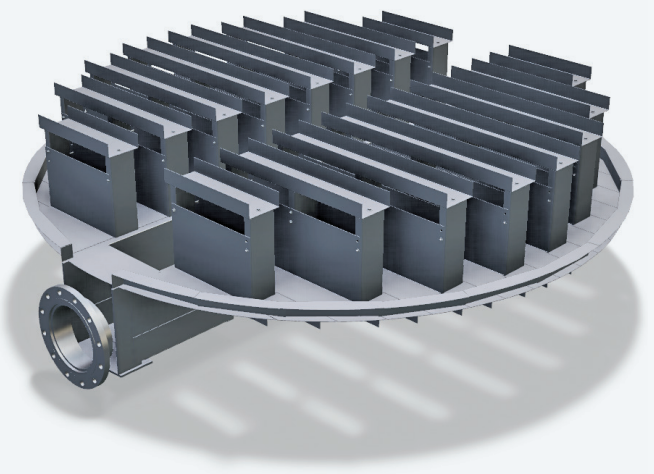

## Model 622 Trough Liquid Collector

---

- ▼ Tower diameter: > 6 ft [1800 mm]
- ▼ Support features: Full circumference tower ledge
- ▼ Standard features
  - Seal welded construction
  - Sloped construction reduces residence time and minimizes coking
  - High open area minimizes pressure drop
  - Emergency overflow
  - Thermal expansion without excessive leakage
  - Preferred design for the overflow collector in deepcut vacuum crude towers
  - Total or partial draw

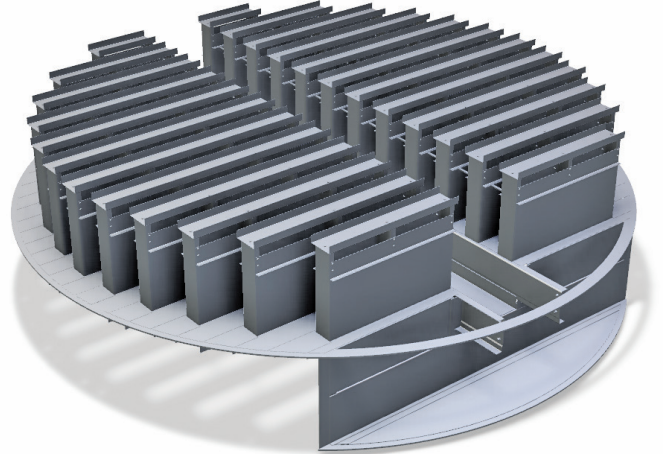

## Model 633 Vane Liquid Collector

---

- ▼ Tower diameter: > 2.5 ft [760 mm]
- ▼ Support features: Full circumference annulus or body flange mounted
- ▼ Standard features
  - Low vapor phase pressure drop
  - Eliminates separate feed pipe by feeding liquid directly to annulus for complete mixing
  - Vane style tailored to process requirements
  - Pipe or box downcomers
- ▼ Optional features
  - Total liquid cross-mixing

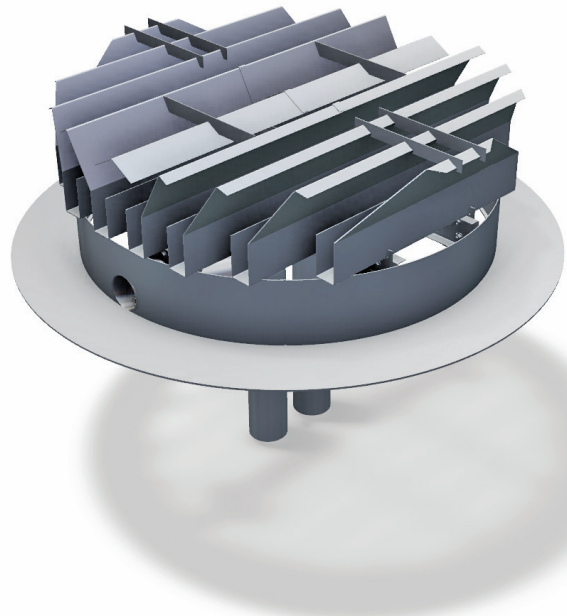



## BED LIMITERS

For structured packing, bed limiters are recommended to prevent packing displacement when there is the potential for upset conditions. Structured packing columns that operate at a low pressure drop with a low percentage of flood and are not prone to sudden vapor surges do not require a bed limiter. For random packing, a bed limiter or anti-migration device is always recommended because conditions that result in the fluidization of some or all packing at the top of a random packed bed are difficult to predict. Refer to Bed Limiters on page 27 of the Technical Guide for more information.

### Model 803 Structured Packing Bed Limiter

- ▼ Support features: Wall clips or jack screws
- ▼ Standard features
  - Designed for non-interference with liquid from distributor above
  - Integrated with liquid distributor in small diameters
  - Withstands 50 lb/ft<sup>2</sup> [0.024 bar] upward force
  - Used with INTALOX® high performance liquid distributors
- ▼ Optional features
  - Increased uplift resistance



### Model 805 Random Packing Bed Limiter

- ▼ Support features: Rests on packing; requires no vessel attachments
- ▼ Standard features
  - Designed for non-interference with liquid from distributor above
  - Withstands 50 lb/ft<sup>2</sup> [0.024 bar] upward force
  - Used with INTALOX high performance liquid distributors
- ▼ Optional features
  - Increased uplift resistance

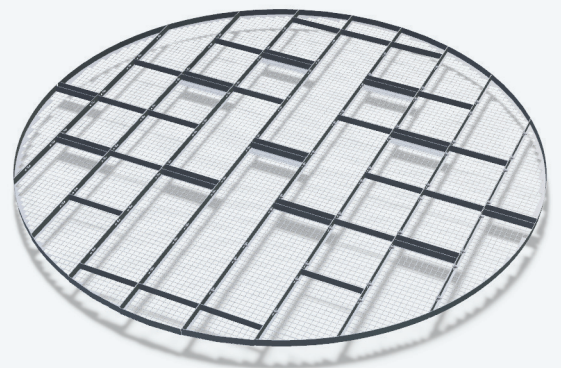

### Model 825 Random Packing Bed Limiter

- ▼ Support features: Full circumference tower ledge, wall clips, or jack screws
- ▼ Standard features
  - Withstands 50 lb/ft<sup>2</sup> [0.024 bar] upward force
  - Used with standard liquid distributors
- ▼ Optional features
  - Increased uplift resistance

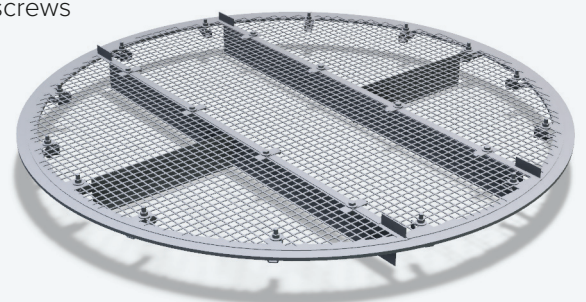

# SUPPORT PLATES

Every packed bed will need a support. Two critical factors to be considered in the design of a packing support are:

- The ability to physically retain and support the packed bed under column operating conditions.
- A high percentage of open area to allow unrestricted countercurrent flow of downcoming liquid and upward flowing vapor so the packing capacity is not limited.

## Model 802 Structured Packing Support Grid

---

- ▼ Tower diameter: No restriction
- ▼ Support features: Full circumference tower ledge or wall clips
- ▼ Standard features
  - Free and uniform passage of liquid and vapor
  - Bolted grid sections
- ▼ Optional features
  - Increased uplift resistance
  - Ledge clamps
  - Midspan beams

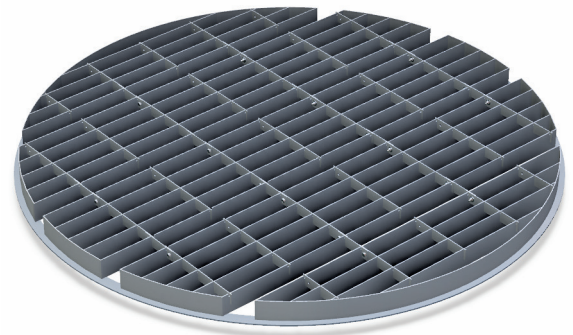

## Model 804 Random Packing Support Plate

---

- ▼ Tower diameter: > 3 ft [900 mm]
- ▼ Support features: Full circumference tower ledge
- ▼ Standard features
  - Gas injection design for free and uniform passage of liquid and vapor
  - Beam sections connected with bolting
  - Ledge clamps
- ▼ Optional features
  - Midspan beams

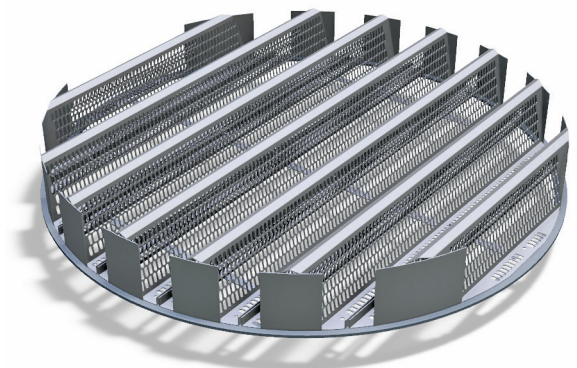

## Model 814 Random Packing Support Plate

---

- ▼ Tower diameter: 1-4 ft [300-1200 mm]
- ▼ Support features: Full circumference tower ledge or wall clips
- ▼ Standard features
  - Gas injection design for free and uniform passage of liquid and vapor
  - Beam sections connected with bolting
- ▼ Optional features
  - Single-piece construction
  - Ledge clamps

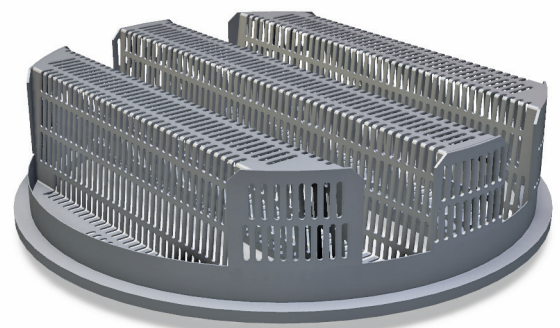

## INTERNALS FOR OFFSHORE APPLICATIONS

Koch-Glitsch has established a leading role with unique packed tower internals designs for mass transfer columns that perform successfully in the severe conditions encountered in floating production storage and offloading (FPSO) platforms or vessels. Koch-Glitsch can provide mass transfer capabilities for FPSOs and total turnkey plants for deaeration of seawater. Koch-Glitsch has completed an extensive liquid distribution test program of its specialized designs using a rig that reproduces the roll and pitch sea motions typically experienced by columns on an FPSO. This testing provides the confidence that the designs will perform satisfactorily to maximize column performance under adverse conditions and for a wide range of operating rates. Koch-Glitsch has extensive worldwide experience providing mass transfer equipment for offshore applications, such as gas dehydration, sour gas treatment, and gas fractionation. Locations include the North Sea, South China Sea, the Gulf of Mexico, and the Campos Basin offshore Brazil.

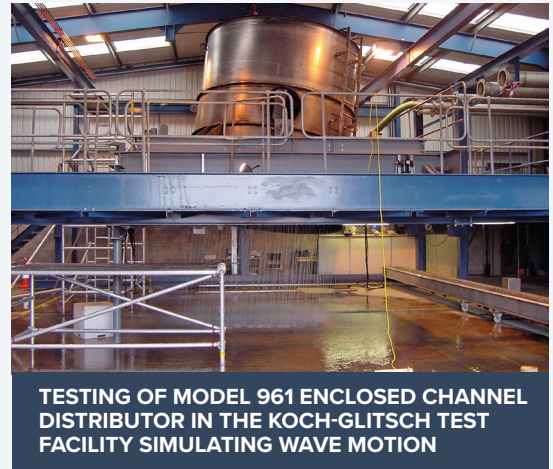

**TESTING OF MODEL 961 ENCLOSED CHANNEL DISTRIBUTOR IN THE KOCH-GLITSCH TEST FACILITY SIMULATING WAVE MOTION**

### Model 961 Channel Distributor

- ▼ Metering device: Orifices in channel bottom
- ▼ Liquid rates: 1-30 gpm/ft<sup>2</sup> [2.4-73 m<sup>3</sup>/h/m<sup>2</sup>]
- ▼ Tower diameter: > 2.5 ft [760 mm]
- ▼ Support features: Beams
- ▼ Redistribution: Separate liquid collector
- ▼ Standard features
  - Turndown ratio determined by height limitations and motion dynamics
  - Designed for offshore applications subject to tilt and motion
  - Enclosed channels allow for high liquid head to reduce flow variation

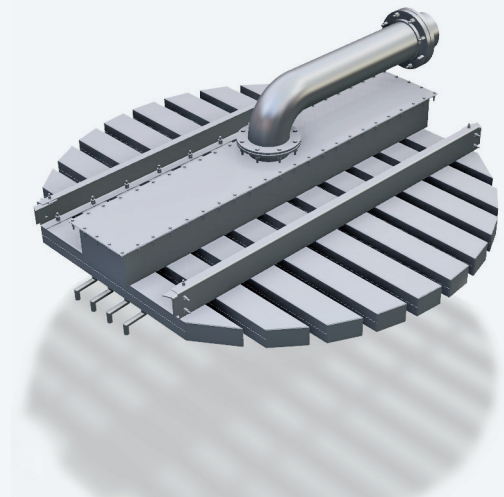

### Model 613 Deck Liquid Collector

- ▼ Support features: Full circumference tower ledge
- ▼ Standard features
  - Deck sloped for quick drainage of liquid
  - Vapor risers sufficiently tall to prevent entrance of sloshing liquid
  - Center sump location
  - Box downcomers
- ▼ Optional features
  - Pipe downcomers

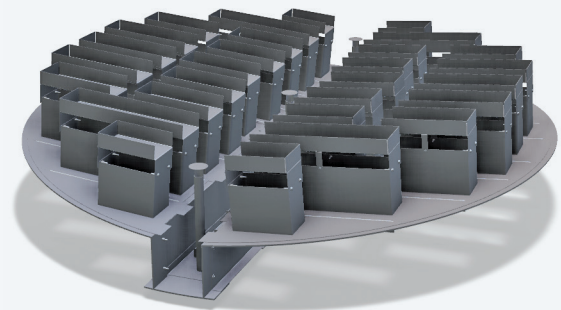

# INTERNALS FOR LIQUID-LIQUID EXTRACTION

Liquid-liquid extraction is sometimes used in applications where distillation may not be suitable. Such systems include solutions that form azeotropes, have very close boiling points, or contain high molecular weight organic materials that may degrade at high temperatures. Packing is used in counter-current liquid-liquid contactors with special internals to disperse one of the phases. Selection and arrangement of the internals depends on which phase (light or heavy) is continuous and which is dispersed. In all cases, feed pipes directing the feed, light and heavy, are recommended to control velocity.

## Model 534 Disperser/Support Plate

- ▼ Phase rates
  - Maximum continuous: 7.5 gpm/ft<sup>2</sup> [18 m<sup>3</sup>/h/m<sup>2</sup>]
  - Dispersed: 2.1-72.3 gpm/ft<sup>2</sup> [5-175 m<sup>3</sup>/h/m<sup>2</sup>]
- ▼ Tower diameter: 1-10 ft [300-3000 mm]
- ▼ Support features: Full circumference tower ledge
- ▼ Standard features
  - Used with random packing
  - Maximum dispersed turndown ratio 5.5:1
  - Supports packed bed and disperses light phase into heavy phase
  - Dump tubes allow heavy phase to travel downward through the plate
  - Light phase forms a pool under the plate and orifices generate droplets
  - Ledge clamps
- ▼ Optional features
  - Larger tower diameter

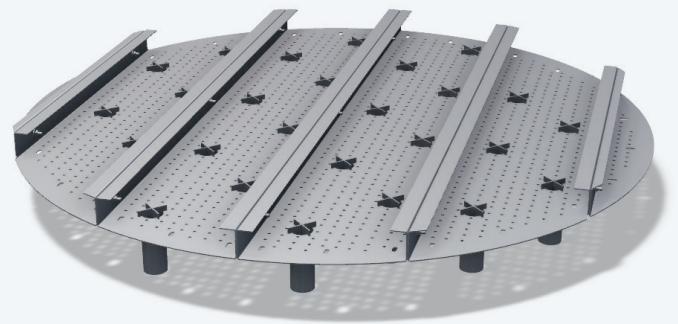

## Model 535 Disperser Plate

- ▼ Phase rates
  - Maximum continuous: 7.5 gpm/ft<sup>2</sup> [18 m<sup>3</sup>/h/m<sup>2</sup>]
  - Dispersed: 2.1-72.3 gpm/ft<sup>2</sup> [5-175 m<sup>3</sup>/h/m<sup>2</sup>]
- ▼ Tower diameter: 1-10 ft [300-3000 mm]
- ▼ Support features: Full circumference tower ledge
- ▼ Standard features
  - Used with random packing
  - Supports packed bed and disperses heavy phase into light phase
  - Riser tubes allow light phase to pass up through the plate
  - Heavy phase forms a head on the top of the plate, and orifices generate droplets
  - Ledge clamps
- ▼ Optional features
  - Larger tower diameter

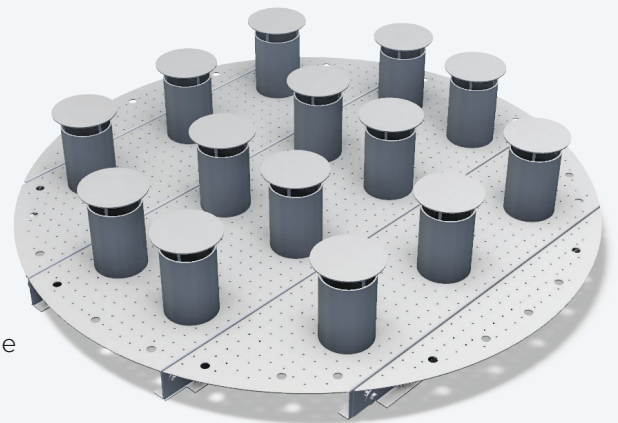

## Model 544 Dispersed Phase Feed Pipe

- ▼ Tower diameter: No restriction
- ▼ Support features: Wall clips or beams
- ▼ Standard features
  - PTFE gaskets
  - Prevents excessive turbulence at the phase boundary at the disperser plate
  - Controls feed velocity
  - Correct positioning of discharge points to minimize disturbance
- ▼ Optional features
  - Alternate gasket material
  - All flanged construction



## Model 545 Continuous Phase Feed Pipe

- ▼ Tower diameter: No restriction
- ▼ Support features: Wall clips or beams
- ▼ Standard features
  - PTFE gaskets
  - Controls feed velocity to prevent excessive disturbance of the heavy/light phase interface
- ▼ Optional features
  - Alternate gasket material
  - All flanged construction

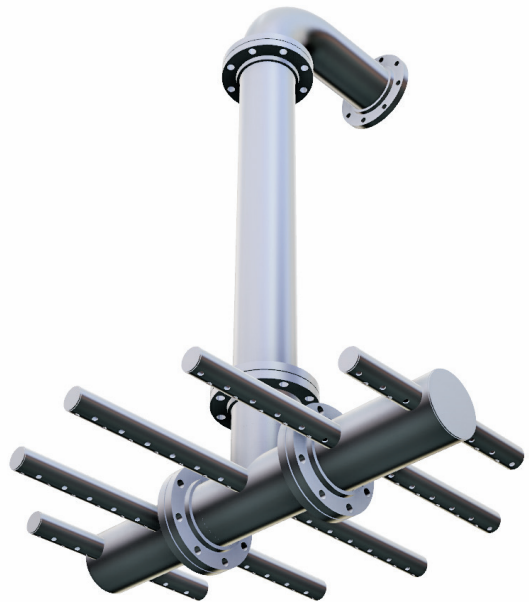

# ENGINEERED BEAMS

The sectionalized beam and pinned truss technologies are patented supports developed by Koch-Glitsch to enhance process performance and reduce equipment installation time. The lighter individual components of these innovative designs are safer to handle, easier to install, and reduce field welding. The pinned assemblies provide superior mechanical rigidity.

- ▼ Pin transfers load between upper and lower sections
- ▼ Bolts align holes for pins; not intended for load transfer
- ▼ Open construction does not restrict vapor flow
- ▼ Improved strength-to-weight ratio for longer spans
- ▼ Reduced installation time
  - Sections designed to fit through manways
  - Less welding in the tower
  - Also applied to tray installations

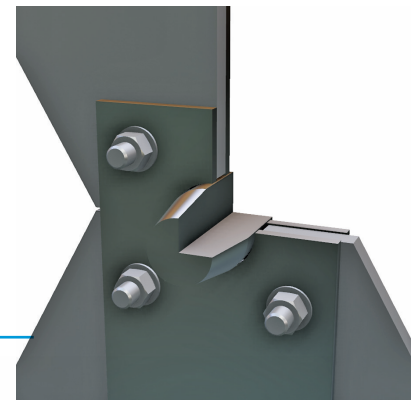

## Model 840 Sectionalized Beam

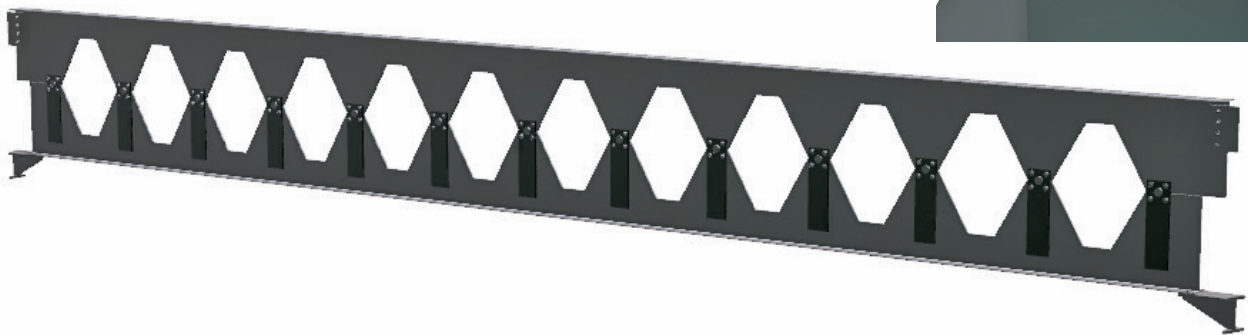

## Model 850 Pinned Truss

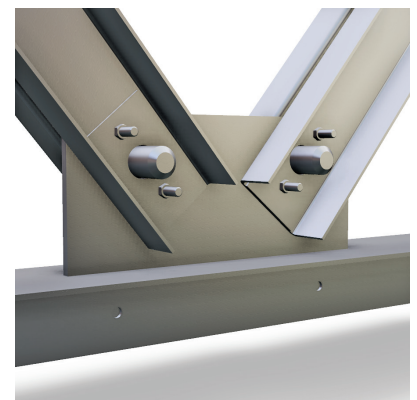
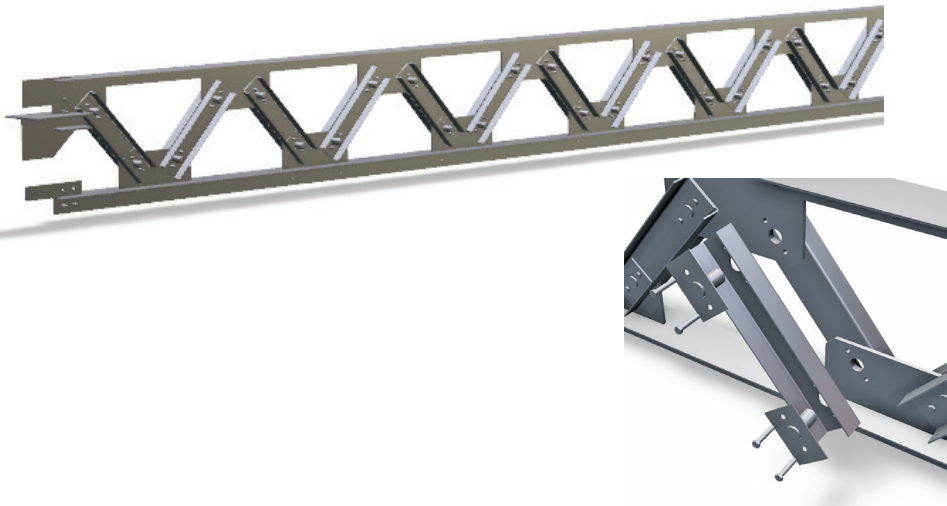

## TECHNICAL GUIDE

Key contributors to good performance are proper liquid and vapor distribution. Koch-Glitsch has dedicated years to extensive research to develop efficient, high-capacity packed towers. Recognizing that not all packed towers require state-of-the-art liquid distribution uniformity, Koch-Glitsch also offers a wide range of standard-style internals. The following sections describe the importance of liquid and vapor distribution and the circumstances in which INTALOX® Packed Tower Systems technology should be applied versus standard-style internals that are appropriate in less demanding services. Additional sections provide more information regarding liquid collectors, bed limiters, support plates, feed devices, and construction details.

## INTALOX® PACKED TOWER SYSTEMS TECHNOLOGY

The key to predictable packed tower performance is a design that includes packing and associated internals that work together as a system to provide optimal performance. This is the foundation of the INTALOX Packed Tower Systems technology.

## LIQUID DISTRIBUTION AND REDISTRIBUTION

When high performance tower packings were introduced in the 1970s and 1980s, the design deficiencies of the distributors available at the time became very apparent. In response, Koch-Glitsch developed distributors with features that corrected those deficiencies. These important features are well understood by Koch-Glitsch and are incorporated into the INTALOX high performance distributors. Koch-Glitsch offers two categories of liquid distributors (high performance and standard) to meet the requirements of specific applications. In determining which category to choose, it is necessary to know the sensitivity of the process and whether the liquid distribution will significantly affect the overall tower performance. An ideal distributor/redistributor possesses the following attributes, each having a specific effect on the overall performance of the packed tower:

- |  |   |
|--|---|
| <ul style="list-style-type: none"> <li>▼ Uniform liquid distribution</li> <li>▼ Proper operation through its required turndown range</li> <li>▼ Low vapor phase pressure drop</li> <li>▼ Resistance to plugging or fouling</li> <li>▼ Optimal use of vessel height</li> <li>▼ Minimal liquid residence time</li> <li>▼ Mixing capability for redistribution to the next bed (may require separate liquid collector)</li> </ul> | <p>Liquid and vapor maldistribution are the leading causes of packed tower failures that are not due to operational issues.</p> <ul style="list-style-type: none"> <li>▼ Premature flooding caused by localized high vapor velocities or excessive liquid hold-up</li> <li>▼ Coking on dry packing at high temperatures</li> <li>▼ Fouling material not flushed away on under-wetted packing</li> <li>▼ Lower than expected efficiency due to vapor/liquid channeling and reduced liquid/vapor contact</li> </ul> |
|--|---|

Limitations on bed depth and the need to introduce feeds or draws on the column lead to the requirement for redistribution of liquid. Important factors to keep in mind with the introduction of a liquid feed are the temperature and composition of the feed stream compared to the internal column liquid. Normally, unless the feed rate is small compared to the flow rate of the internal column liquid, it is desirable to mix the feed with the internal liquid to provide compositional uniformity before distributing it to the packed bed below. It is also advisable to mix the feed stream and internal liquid when their temperatures are significantly different.

When a packed column is designed with a large number of theoretical stages or transfer units, a constant liquid to vapor ratio (L/V) is needed to achieve the best overall column performance. Redistribution of the liquid ensures that the L/V ratio is maintained, while cross-mixing between beds ensures uniform composition. Based on Koch-Glitsch's operating experience, a limit of 15 theoretical stages per bed provides good packing performance. In cases where a very large number of stages is required, that limit may be extended to 20 theoretical stages or transfer units; however, proper redistribution of the liquid is critical. Koch-Glitsch has special designs to handle these situations.

## Liquid Distribution Quality

The optimum performance of INTALOX® high performance distributors is the result of applying the following design criteria:

- ▼ Drip points located in a uniform pattern
- ▼ Drip point positions uninterrupted by vapor risers or mechanical supports and joints
- ▼ Drip points properly spaced with respect to the vessel wall
- ▼ Minimal variation in flow between drip points

Koch-Glitsch developed a distributor rating system to quantify distributor performance or "distribution quality". The rating uses a percentage scale with theoretical perfection set at 100%. Low percentage ratings reflect areas of the column that are receiving liquid flow significantly different from other areas. The chart to the right demonstrates the overall effect that can be expected with various levels of distribution quality. In addition to properly locating the drip points, it is important to maintain minimal flow

variation between points. This can be achieved by adherence to strict tolerances on hole size and flatness of plates. Liquid velocities are limited to minimize the formation of gradient heads on the distributor. Finally, the feed device is designed to deliver liquid to the distributor without inducing turbulence or gradients. As a general rule, INTALOX high performance distributors are recommended when using high performance packing, such as INTALOX® ULTRA random packing or FLEXIPAC® HC® structured packing, to ensure the highest efficiency and capacity are achieved. Likewise, it may be suitable to use standard liquid distributors with previous generation packings where the separation demands are lower. INTALOX high performance distributors are always recommended for:

- ▼ Distillation services with a large number of theoretical stages per bed
- ▼ Distillation systems with low relative volatility between the key components
- ▼ High product purity requirements
- ▼ Distillation services operating near the minimum reflux ratio or close to an equilibrium pinch point
- ▼ Absorption or stripping applications with close approach to equilibrium
- ▼ Heat transfer applications with close approach temperatures

The maximum maldistribution that can be tolerated in a packed bed is strongly dependent on the product composition, the relative volatility, the liquid to vapor ratio, etc. Koch-Glitsch considers all these aspects as well as others while designing packed columns.

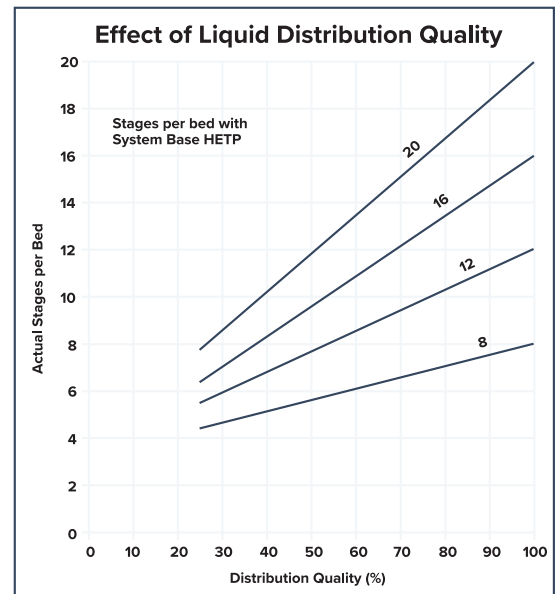



## Drip Point Density

The drip point density has an influence on the efficiency of the uppermost part of a packed bed. With the most commonly used sizes of random and structured packings, the effect of the drip point density is relatively minor. However, drip point density does have a considerable effect on the performance of high surface area, very high efficiency packings. The table below details the guidelines for drip point count based on the high performance packing to be used.

Packing Type	Minimum Recommended Drip Point Density				
	5.5 pts/ft <sup>2</sup> [60 pts/m <sup>2</sup> ]	9 pts/ft <sup>2</sup> [100 pts/m <sup>2</sup> ]	12 pts/ft <sup>2</sup> [130 pts/m <sup>2</sup> ]	15 pts/ft <sup>2</sup> [160 pts/m <sup>2</sup> ]	20 pts/ft <sup>2</sup> [215 pts/m <sup>2</sup> ]
Wire Gauze Packing				AX, BX, CY	DX, EX
FLEXIPAC® and FLEXIPAC® HC® structured packing	2.2Y, 2.5Y, 3Y, 3.5Y, 4Y	1.6Y, 350Y, 250Y, 2Y	700Y, 500Z, 1Y		
INTALOX® structured packing	3T, 4T, 5T	1T, 1.5T, 2T			
INTALOX® ULTRA random packing	A, L, O, X	T			
Other random packings	Nominal 1" [25 mm] and larger	Smaller than nominal 1" [25 mm]			

## Distributor Orifice Sizing

### Fouling

For a distributor to perform correctly, it is important that the metering devices do not become fouled. There are several mechanisms and sources of fouling materials: polymerization, coking, scale, construction debris, sediment, rust flakes, etc. All precautions should be taken to eliminate fouling materials outside of the column because external strainers and filters are far easier to clean than distributors. In some cases, it is not possible to eliminate all external fouling sources. In other cases, the source of the fouling material can be within the column itself. Therefore, the choice of the distributor should be dependent on the nature of any fouling. The list below ranks the fouling resistance of various metering devices and arrangements for liquid distributors, starting at the left with the most resistant.

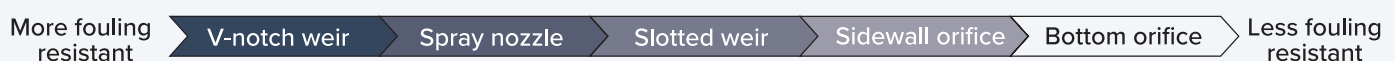

Distributors with weirs for liquid metering will not meet the criteria for flow variation for an INTALOX® high performance distributor.

## Operating Range

A distributor will give its best performance at and around 100% of the design liquid flow rate. As the rate decreases and the liquid head drops, levelness of the distributor as well as gradients in liquid level become a larger percentage of the operating liquid head. At some turndown rate, the flow variation from point to point will fall outside of acceptable limits. For high turndown requirements, multi-level orifices or slotted weirs may be used with some INTALOX® distributor designs as well as traditional distributor styles. It should be noted, however, that when using these metering devices, the flow variation will be higher throughout all or part of the operating range compared to a single orifice design. In gravity-fed distributors, the orifice size is dependent upon the drip point density, the specific liquid rate, and the height of the liquid. For a single level orifice, with an operating range of 60 to 120% of the design flow, the approximate orifice size is indicated in the graph to the right.

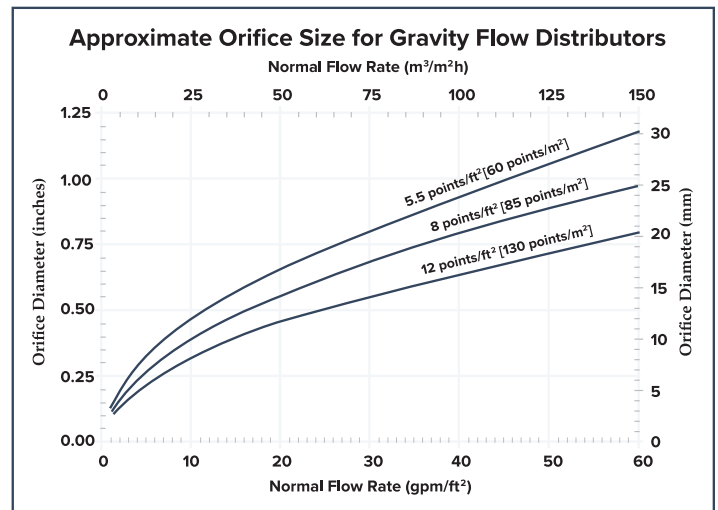

## LIQUID COLLECTORS

Liquid collection between packed beds is frequently required. The reasons for using liquid collectors are varied; therefore, the design is tailored to every application. Examples of situations where liquid collection might be needed are summarized below.

- ▼ Withdrawing liquid products
- ▼ Pumparounds – side reboilers / coolers
- ▼ Mix and remix liquid from an overhead packed bed with feed liquid that does not match in composition or temperature
- ▼ Consolidate liquid from packed bed above for introduction to distributor
- ▼ Change in column diameter between packed beds
- ▼ Change in number of passes between trayed sections
- ▼ Transition between tray to packed bed and packed bed to tray sections

There are many design parameters that must be considered when specifying a liquid collector:

- ▼ Gaskets are supplied with bolted collectors
- ▼ Total draw collectors and those in low liquid rate applications should be seal welded
- ▼ Gas riser covers should be designed to segregate falling liquid from high velocity vapor exiting the risers
- ▼ Gas risers should be properly arranged to provide good vapor distribution
- ▼ Draw sumps should be sized for self-venting flow
- ▼ Sumps can be applied to reduce the residence time and avoid excessive load on the collector
- ▼ Downcomers and pipes must be designed to prevent vapor by-pass
- ▼ Collectors must be designed with the same operational flexibility as the other tower internals

Consult your Koch-Glitsch representative to determine the best solution for your requirements.

## LIQUID COLLECTORS

### Structured Packing

Bed limiters for structured packing are recommended to prevent packing displacement when there is the potential for upset conditions. Uplift resistant designs are available for towers that are prone to upsets. Refer to Koch-Glitsch's Severe Services brochure (KGSP-2) for details. Many columns operate at a low pressure drop and a low percentage of flood and are not prone to sudden vapor surges. In these cases, bed limiters are not required. In some cases, where upset conditions are not a concern, the Model 883 bed limiter/liquid distributor support for structured packing may act as a support for a trough-type liquid distributor. Except in the case of the Model 883, the bed limiter is not included as part of any other support device. Only a non-interfering bed limiter design should be used with INTALOX® high performance distributors.

### Random Packing

A packing retention device is recommended whenever there is the potential for sufficient vapor load to fluidize the top of a packed bed. As packing approaches and enters an upset or flooding condition, the pressure drop rises quickly and often uncontrollably. If a packed column goes into flood, this rate will nearly always result in the top of the bed being fluidized. Because conditions that result in the fluidization of some or all of the packing at the top of a bed are difficult to predict, a packing retention device is always recommended for random packings. Bed limiters attached to the vessel either by clips or clamped to a support ring generally require integral structural members. These structures can interfere with the liquid distribution pattern, and these types of bed limiters are not recommended for use with high performance liquid distributors. Only a non-interfering bed limiter design should be used with INTALOX high performance distributors. Another method of retaining packing is to use anti-migration bars at the base of the vapor risers of a liquid distributor. For most distributor designs using round or rectangular vapor risers, this option is available provided the distributor is not continuously subjected to high vapor load.

## SUPPORT PLATES

Every packed bed will need a support. Two critical factors to be considered in the design of a packing support are:

- ▼ It must physically retain and support the packed bed under operating conditions in the column including, but not limited, to packing type and size, design temperature, bed depth, operating liquid holdup, material of construction, corrosion allowance, material buildup in the bed, and surge conditions.
- ▼ It must have a high percentage of open area to allow unrestricted countercurrent flow of downcoming liquid and upward flowing vapor

Pressure drop calculations for all Koch-Glitsch packings include the pressure drop of the properly designed support. All supports are designed to handle the flow rates specified at the time of order placement and will not limit the capacity of the packing they retain. Random packing uses a gas-injection type support that provides separate passages for liquid and vapor flow so that the two phases do not compete for the same opening. Packing elements are retained with specific slot openings while the contour of the support provides a high percentage of open area. The inherent construction of structured packing allows it to be supported by a simple open grid structure. FLEXIGRID® severe service grid packing may utilize a beam and/or an open grid structure.

# FEED DEVICES

## Liquid Only Feeds

Liquid only feeds are considered to have less than 1% vapor by volume. Among the factors Koch-Glitsch considers in designing a liquid feed device are type of distributor, expected distributor performance, flow rate, operating range, degree of sub-cooling, and whether mixing with liquid coming from the packed bed above is required. When the feed or reflux liquid is significantly sub-cooled, a specially designed feed arrangement may be required. A liquid with a wide temperature gradient, even if properly distributed to a packed bed, can induce mal-distribution due to uneven condensation. The feed arrangement for these conditions depends on the distributor type. Please consult a Koch-Glitsch technical representative for recommendations.

## Liquid/Vapor and Flashing Feeds

For mixed liquid/vapor or flashing feed devices above a distributor, the selection depends on the distributor type, liquid and vapor flow rates, turndown, column height required for disengagement and vapor distribution, as well as the degree of mixing of the inlet liquid with the internal column liquid. In all cases, separating the vapor and the liquid phases is a primary concern. In some cases, the requirements for additional pre-distribution may alter certain distributor designs.

## Vapor Only Feeds

Two factors must be considered in choosing the proper device for a vapor only feed.

1. The kinetic energy of the inlet vapor must be considered in relation to the pressure drop in the packed bed, the feed nozzle arrangement, and the tower separation requirements.
2. If there is a gross mismatch in the composition and/or temperature between the inlet vapor stream and bulk vapor flow, mixing of the two vapors optimizes the performance of the packing above.

Specific equipment for vapor distribution may not be required if sufficient column height is available for equalization or if the pressure drop in the packed bed is sufficient to provide proper vapor distribution.

## Reboiler Returns or Gas Inlets

To determine the need for and the type of device required for a reboiler return, the first step is to consider the condition of the stream and its kinetic energy. For vapor only returns or gas inlets, the kinetic energy of the inlet vapor or gas must be considered in relation to the pressure drop in the packed bed, the feed nozzle size and arrangement, as well as the tower separation requirements. For a mixed liquid/vapor or suppressed flash reboiler return stream, the selection of the device depends on flow rate, ratio of liquid and vapor flow, flow regime, nozzle size and arrangement, column height needed for vapor disengagement, and the tower separation requirements.

## Computational Fluid Dynamics (CFD) Modeling

Good vapor and gas distribution is essential to achieve superior separation efficiency. Particularly in refinery towers, poor vapor distribution can be a major source of coke formation resulting in frequent unit shutdowns. Koch-Glitsch uses modern Computational Fluid Dynamics (CFD) modeling technology to analyze the performance of existing equipment and to develop new improved designs. This involves computer modeling of the 3-dimensional configuration of the column internals to provide detailed predictions of fluid flow (velocity profiles, etc). A commercially available CFD software package is used in conjunction with expertise developed by Koch-Glitsch to analyze vapor or gas and liquid distributors as well as packing performance.

Koch-Glitsch offers CFD services for the following tasks:

- ▼ Development and optimization of new mass transfer equipment
- ▼ Troubleshooting or analysis of existing equipment
- ▼ Confirmation of equipment designs prior to fabrication and installation.

## CONSTRUCTION DETAILS

### Metal

Tower internals are available in any formable, weldable sheet metal material. Where pipe is involved in the design, the choice must be any weldable metal for which pipe and flanges are readily available. The following materials are most often used for tower internals:

- ▼ Carbon steel (not recommended for liquid distributors)
- ▼ Stainless steel (low carbon content is preferred); Ferritic, Austenitic, Duplex, Martensitic
- ▼ Nickel and copper alloys
- ▼ Aluminum, Titanium, and Zirconium

Internals are not stress relieved or annealed and do not typically conform to pressure vessel standards. Internals fabricated from sheet metal materials will be supplied in “as-sheared” condition. Designs including corrosion allowances are available for many tower internals. Designs with corrosion allowances are not recommended for liquid distributors because corrosion of the metering device will affect performance. Designs for INTALOX® high performance liquid distributors are not available with corrosion allowances. Material certification is available for all fabricated internals. Positive Material Identification (PMI) testing is available by special request. Pickling and passivation are available on request.

### Bolting and Gasketing

With the exception of specific sizes for pipe flanges, all fasteners will be 3/8 in [10 mm] unless otherwise specified. Bolting will conform to AISI standards. Bolting conforming to ASME specifications is available by special request. For multi-piece tower internals requiring gasketed joints, many choices of gasket material are available. Where gasketing is required, braided fiberglass tape is supplied as the standard for linear joints. Depending on the service, FLEXITALLIC® SF2400, expanded PTFE, or spiral wound stainless steel with flexible graphite filler gaskets are supplied as the standard for flanged connections. Other gasket materials are available by special request.

### Flanges

Flanges are the standard connections for tower internals using pipe sections or branches and where the connections are inside the column pressure boundary. These flanges may be standard machined pipe flanges with 150 psi [PN 10] rating or flanges fabricated by Koch-Glitsch from plate, depending on material of construction, size, and availability. In some cases for pipe connections with diameters under 4 in [100 mm], threaded connections may be used. Please include specific requirements concerning flange type, rating, or pipe schedule specifications at the time of inquiry.

### Manway Access

Most tower internals are designed in sections to pass through vessel manways (large beams and pipes may be shop installed prior to completion of the vessel). Tower internals are designed to pass through a vessel manway of 20 in [500 mm] minimum inside diameter, unless otherwise specified. Larger manways often provide the ability to increase turndown ratio on distributors and/or to optimize the design of components for faster, easier installation. Please provide manway locations and sizes at the time of inquiry.

### Scope of Supply

For the fabricated internals in this brochure, Koch-Glitsch supplies all removable parts. The internals do not include vessel attachments for connection or support, unless specifically stated in the item description. Vessel attachments are offered separately. Examples of vessel attachments that may be required are:

- ▼ Support rings and wall clips for support
- ▼ Sump frames
- ▼ Internal flanges at feed inlet nozzles
- ▼ Liquid collector annulus

## OTHER TOWER INTERNALS

Over the years, Koch Engineering Company, now Koch-Glitsch, has developed and acquired proven internals and technology for packed towers from Glitsch and Saint-Gobain NorPro. As a result of these acquisitions, Koch-Glitsch has identified and offers the best products and technology from each company. Exact replacements of any column internals formerly sold by Koch, Glitsch, or Norton (NorPro) are available upon request and can be designed and built to their original specifications.

The following is a partial list of other tower internals not specifically covered in detail in this brochure. For further information concerning these models, contact a Koch-Glitsch representative.

Device	Model	Description
Feed Devices	795	Suppressed flash vapor feed distributor for flashing feed or suppressed vaporization reboiler return
	798	Vapor inlet designed for FCC Main Fractionators for extreme fouling resistance
Bed Limiters	815	Anti-migration screen used to separate two different random packing sizes in a single bed
	845	Bed limiter designed for random packed beds using spray nozzle distributors to minimize disruption of spray pattern at the top of the bed
Support and Tower Attachments	800	Annular support ring or support ring segment
	801	Free Flow support ring
	810	Support beam – fabricated channel or I-beam
	811	Free Flow support beam
	820	Support truss – fabricated truss or lattice beam
	828	Drip ring (wall wiper)
	830	Beam seats and clips
	858	Rosette style wall wiper

### Minimum Support Ring Widths

All dimensions are expressed in inches [millimeters]

Tower I.D.	Internals resting on or clamped to support ring	Internals through-bolted or using leveling screws
Up to 18.0 [up to 457]	0.75 [20]	1.5 [40]
18.1 - 24.0 [458 – 610]	1.0 [25]	1.5 [40]
24.1 – 48.0 [611– 1220]	1.5 [40]	2.0 [50]
48.1 – 72.0 [1221 – 1830]	2.0 [50]	2.0 [50]
72.1 – 96.0 [1831 – 2440]	2.5 [65]	2.5 [65]
96.1 – 144.0 [2441 – 3660]	3.0 [75]	3.0 [75]
144.1 – 168.0 [3661 – 4270]	3.5 [90]	3.5 [90]
168.1 – 216.0 [4271 – 5490]	4.0 [100]	4.0 [100]
216.1 – 240.0 [5491 – 6100]	4.5 [115]	4.5 [115]

If the support ring size is other than these listed above, special consideration must be given to the plate diameter and vessel tolerances.

# INDEX

Table of Contents	.....	2
Introduction	.....	2
High Performance Liquid Distributors	Model 106/107 Pan Distributor.....	3
	Model 116/117 Deck Distributor.....	3
	Model 136/137 Channel Distributor.....	4
	Model 141 Tubular Distributor.....	4
	Model 156 Trough Distributor.....	5
	Model 166 Dual Trough Low Flow Distributor.....	6
	Model 186 Trough Distributor.....	7
	Model 196 Packed Trough Very Low Flow Distributor.....	7
Standard Liquid Distributors	Model 916/917 Deck Distributor.....	8
	Model 941 Pipe Distributor.....	8
	Model 943 Spray Nozzle Distributor.....	9
	Model 985 V-Notch Trough Distributor.....	9
Feed Devices	Model 719 Feed Pipe.....	10
	Model 119 Feed Pipe.....	10
	Model 745 Flashing Feed Pipe.....	11
	Model 705 Flashing Feed Chamber.....	11
	Model 788 V-Baffle Inlet Diffuser.....	12
	Model 755 Flashing Feed Gallery.....	12
	Model 758 Enhanced Vapor Horn.....	13
	Model 746 Pipe Vapor Distributor.....	13
	Model 768 YORK-EVENFLOW Vane Inlet Device.....	14
	Model 716 Deck Vapor Distributor.....	14
Liquid Collectors	Model 611 Deck Liquid Collector.....	15
	Model 621 Trough Liquid Collector.....	15
	Model 622 Trough Liquid Collector.....	16
	Model 633 Vane Liquid Collector.....	16
Bed Limiters	Model 803 Structured Packing Bed Limiter.....	17
	Model 805 Random Packing Bed Limiter.....	17
	Model 825 Random Packing Bed Limiter.....	17
Support Plates	Model 802 Structured Packing Support Plate.....	18
	Model 804 Random Packing Support Plate.....	18
	Model 814 Random Packing Support Plate.....	18
Internals for Offshore Applications	Model 961 Channel Distributor.....	19
Internals for Liquid-Liquid Extraction	Model 613 Deck Liquid Collector.....	19
	Model 534 Disperser/Support Plate.....	20
	Model 535 Disperser/Support Plate.....	20
	Model 544 Dispersed Phase Feed Pipe.....	21
	Model 545 Continuous Phase Feed Pipe.....	21
Engineered Beams	Model 840 Sectionalized Beam.....	22
	Model 850 Pinned Truss.....	22
Technical Guide	INTALOX® Packed Tower Systems technology.....	23
	Liquid Distribution and Redistribution.....	23
	Liquid Collectors.....	26
	Bed Limiters.....	27
	Support Plates.....	27
	Feed Devices.....	28
Construction Details	.....	29
Other Tower Internals	.....	30
	Minimum Support Ring Widths.....	30
Index	.....	31

## KOCH-GLITSCH MAIN OFFICES

### Koch-Glitsch, LP

4111 East 37th Street North  
Wichita, Kansas 67220

tel: (1) 316-828-5110  
fax: (1) 316-828-7985  
info.wichita@kochglitsch.com

### **Emergency Hotlines**

+1-888-562-4911 (mass transfer)

### Koch-Glitsch Italia S.r.l.

Via Torri Bianche, 3A 20871  
Vimercate MB Italy

tel: +39 039 6386010  
fax: +39 039 6386011  
info.vimercate@kochglitsch.com

### **Emergency Hotlines**

+39-06-928-911

### Koch Engineered Solutions Singapore Pte. Ltd.

260 Orchard Road, #11-01/09  
The Heeren  
SINGAPORE 238855

tel: +65-6831-6500  
fax: +65-6835-2031  
info.singapore@kochglitsch.com

### **Emergency Hotlines**

+65-6831-6500

For a complete list of our offices and facilities, visit [koch-glitsch.com](http://koch-glitsch.com).

#### **Trademarks**

The following registered trademarks are owned by Koch-Glitsch, LP in the United States and may be registered in other jurisdictions: FLEXIGRID® severe service grid packing, FLEXIPAC® structured packing, FLEXIPAC® HC® structured packing, INTALOX® Packed Tower Systems technology, INTALOX® ULTRA random packing, KOCH-GLITSCH® and "K" KOCH-GLITSCH (logo). The following trademarks are owned by Koch-Glitsch, LP in the United States and may be registered in other jurisdictions: YORK-EVENFLOW vane inlet device and YOU CAN RELY ON US. All other trademarks, service marks, or registered trademarks that appear in this document are the trademarks or service marks of their respective owners. For related trademark information, visit [www.koch-glitsch.com/legal-notices/trademarks](http://www.koch-glitsch.com/legal-notices/trademarks).

#### **Patents**

The following technologies are protected by one or more patents in the USA; other foreign patents may be relevant: Column Internals (US7114709, US7125004, US8317166, US9089787, US9625221), FLEXIPAC® HC® structured packing (US5632934, US6478290), INTALOX® ULTRA random packing (US7722945), and Model 758 Enhanced Vapor Horn (US6889961, US66889962, US7104529).

Available exclusively from Koch-Glitsch, FLEXIPAC® HC® structured packing is protected by US Patent 5,632,934 and other patents worldwide assigned to Praxair Technology, Inc. Koch-Glitsch, LP is the exclusive worldwide licensee of Praxair Technology, Inc. for the manufacture and sale of this packing in all markets except for industrial gas separation.

Legal Notice: The information contained in this bulletin is believed to be accurate and reliable, but is not to be construed as implying any warranty or guarantee of performance.

© 2025 Koch-Glitsch, LP. All Rights Reserved. Bulletin KGMTIG-2, Rev. 01/25. Printed in U.S.A.