

# Tray revamp for demethaniser ethane recovery

As a first step in an ethane extraction plant's operational improvement plan, a tray revamp was performed to improve both tray efficiency and ethane recovery

DARIUS REMESAT *Koch-Glitsch Canada*  
PAUL WENGER *Midstream Engineering Professional*

There are many cryogenic light hydrocarbon processing units operating in Alberta, Canada. These facilities process pipeline-quality natural gas to remove natural gas liquids (NGL), primarily ethane, a valuable feedstock, for Alberta's petrochemical and NGL industries. A study investigated whether any opportunities for operational improvement were available using the existing infrastructure at these locations. A list was generated with different cost levels and ethane recovery improvements. Operators decided first to pursue the lowest-cost, moderate-recovery improvement scenario, which was to replace the top trays in the column with high-capacity, high-efficiency trays.

## Improving ethane recovery at a turbo-expander plant

The two primary factors for improving ethane recovery are:

- Equilibrium (thermodynamics)
- Energy (refrigeration for condensation).

The separation of molecules by distillation (primarily meth-

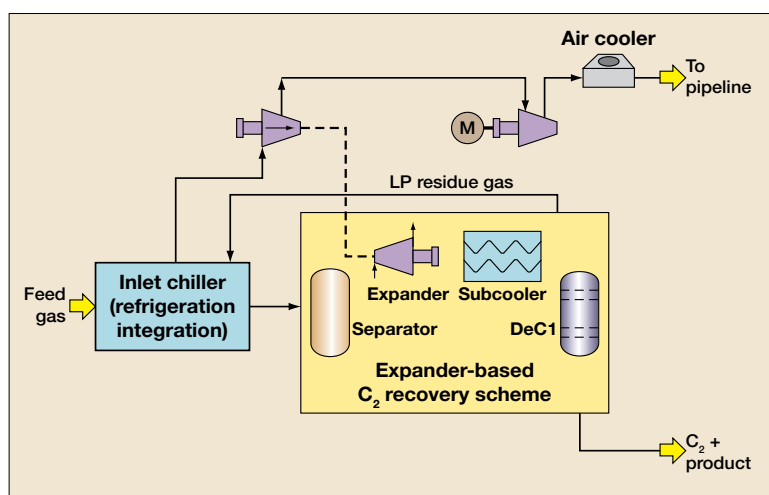

Figure 1 Generalised gas processing scheme for C<sub>2</sub> recovery<sup>1</sup>

ane and ethane at these operating units) is limited by equilibrium conditions within the distillation column. To improve separation within the equilibrium constraints of the distillation tower, tower internals with higher mass transfer efficiency can be employed. In addition, if the tower internals can provide capacity gains, the overall performance of the ethane extraction can be improved tangibly.

For a turbo-expander plant, shown in Figure 1, providing additional energy through

compression of the feed gas can supply further refrigeration via the Joule-Thomson (JT) effect. This added refrigeration translates to an increased top liquid feed, which serves as reflux in this scheme. If the mass transfer internals have the capacity to handle the extra liquid flow, improved ethane recovery results from the contact between the increased liquid and the upcoming vapour flow.

Another related consideration for improving ethane recovery is the composition of the reflux,

which impacts the equilibrium between methane and ethane. Ethane recovery improves as the amount of ethane in the top liquid feed is reduced (that is, it shifts the equilibrium point to allow greater ethane recovery overhead). During operation, improved ethane recovery is achieved and maintained by efficiently converting and using energy; for example, fouling of the heat exchangers limits the optimal use of energy.

### Characteristics of the feed

The feed conditions of Alberta-based processing facilities when compared to feeds in the US Gulf Coast are lower in pressure (consistently below 800 psia), with a lot more CO<sub>2</sub> (~1.1% vs 0.5%), more methane (~89% vs 84%) and fewer C<sub>3</sub>+ hydrocarbons (~2.6% vs 7%). As a consequence, the overall ethane recovery for these plants, with state-of-the-art technology, is lower than with feeds from the US Gulf Coast.

### Process description

The key sections of a typical cryogenic light-ends recovery process unit are shown in Figure 1. A primary separator, expander, subcooler and demethaniser make up the

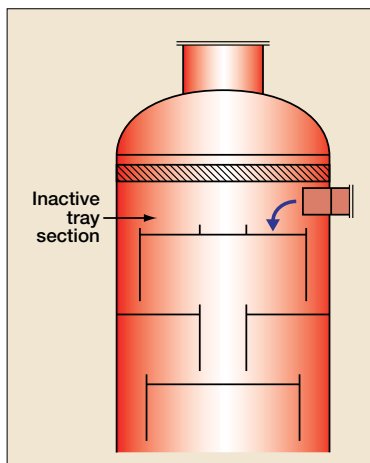

Figure 2 The 8in two-pass top feed inlet nozzle in vessel prior to revamp

cryogenic section of the unit. Specifically, the majority of these processes use the well-known gas sub-cooling process (GSP), in which a small portion of non-condensed vapour is used as the top reflux to the demethaniser after substantial condensation and sub-cooling. The main portion of the feed, typically in the range of 65–70%, is subjected to turbo expansion as usual.

A heat pump takes part of the feed stream and uses it as primary and intermediate reboil for the demethaniser column. A two-sided reboiler approach (heat pump) is used to reduce the need for external

refrigeration. A heat pump design can be recognised by the use of a compressor, cooler for rejecting heat to a high-temperature sink, a JT valve or a second expander and, optionally, a second exchanger to take heat from the low-temperature source.

### Revamp study

The first step in the revamp study was to develop a representative simulation of these plants based on a comprehensive set of test runs that provided the upper and lower limits of production. Table 1 illustrates the various options reviewed, categorises the revamp options as either low or high cost, and groups them according to expected incremental ethane recovery. Each plant processes slight different quantities, so specific returns on investment will differ but all remain positive.

The current maximum recovery of the Alberta-based units is limited due to the feed inlet pressure (<800 psia) and composition of the inlet feed from the local gas fields (high in methane and low in C<sub>3</sub>+ hydrocarbons). However, numerous solutions can be implemented to increase cumulatively the ethane recovery of the entire site. Overall economic evaluations indicated that the tray revamp provided the highest return on investment and so was approved.

### Scope of project

The successful Inside-Out Design Approach<sup>2</sup> used by Koch-Glitsch for revamps was followed to determine the benefits of an internals revamp in the column. Where trays and

#### Analysis of debottleneck opportunities performed

Incremental C <sub>2</sub> recovery	Low cost	High cost
-5% to base recovery 0–3%	Optimise expander flow Use liquid turbines on chilled feed Add 3 to 4 reflux trays	Decouple streams into separators and chillers
+3–5%		Reduce primary separator temperature Provide stripping gas Reduce demethaniser pressure Chill inlet gas
+6–10%		Provide lean reflux (various options)

Table 1

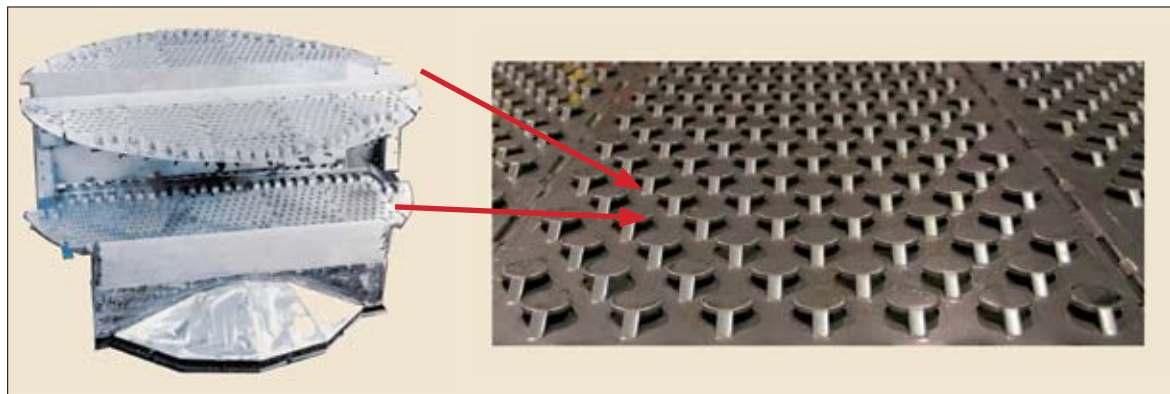

Figure 3 Two-pass Superfrac tray with VG-0 fixed valves — style used in the revamp

demisters were in operation, the project scope was to replace the top three trays in the demethaniser, add an inlet feed distributor and replace the existing Demister mist eliminator. The objective was to capture an additional 3% ethane, which translates into a payback of less than one year because of the low-cost nature of the revamp.

#### Existing internals arrangement

For four operating units, the existing top three trays were either standard-capacity trays or a previous-generation high-capacity tray. The old-style high-capacity tray has increased vapour handling capacity due to the truncated downcomer providing increased active area, and it offers the mass transfer efficiency of a conventional crossflow tray and other high-capacity crossflow trays. These two-pass trays on 24in tray spacing used either standard-diameter moving V-1 or caged type T valves.

In two cases, the demethaniser had no top feed device to distribute the liquid onto the top tray. Figure 2 shows the inlet feed arrangement onto the top tray. The top tray is a two-

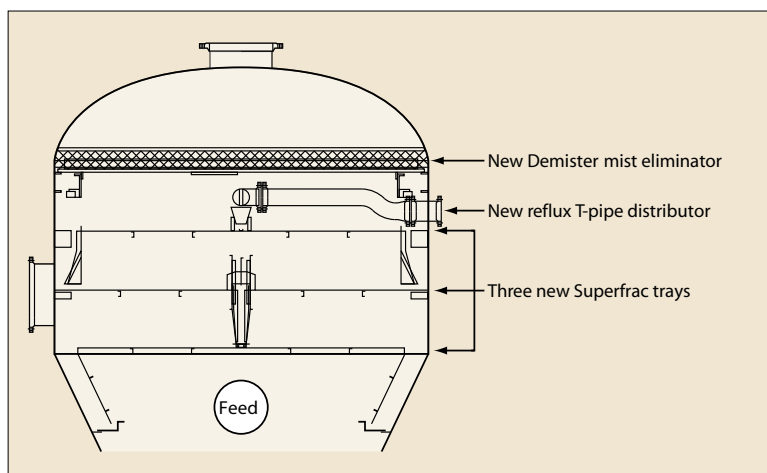

Figure 4 Excerpt of revised vessel elevation drawing

pass design with a centre inlet and side downcomers. The inlet nozzle projected into the vessel to a point past one of the side downcomers, where the liquid was discharged onto one side of the active areas on the two-pass arrangement. This setup greatly reduced the performance of the tray and resulted in abnormally high activity on one side of the tray. Entrainment overhead was a likely result, which reduced overall ethane recovery.

Within the rest of the towers revamped, packing and standard- moving valve trays are in place and were not revamped at this stage

#### Process simulation and proposed equipment

A plant simulation was developed by Koch-Glitsch to match the provided plant test run and incorporate the expected tray efficiencies in the demethaniser. For the cases with the top tray with the liquid feed primarily on one side of the active area, the simulated tray was derated to 50%. The other two trays were given 75% tray efficiency. The developed simulation provided a mass balance closure of 98%. The impact of the mesh mist eliminator not performing to fully de-entrain ethane in the feed was not factored separately into the

Overall incremental ethane recovery calculated post-revamp		
Average, %	Maximum, %	Minimum, %
3.0	7.9	0.2

**Table 2**

simulation. It was hypothesised that with the high froth height on the top tray and the poor top feed liquid distribution, entrainment overhead, even with an intact mesh pad, was causing an additional 1–2% loss in ethane recovery.

Furthermore, Koch-Glitsch developed a simulation to determine the expected benefit of the proposed revamp that incorporated a new feed distributor, three Superfrac trays and a Demister mist eliminator. The new trays would be two-pass for consistency with existing supports and inlet nozzle locations. Since Superfrac trays can provide both increased capacity and efficiency, an overall tray efficiency gain of 10% was included in the simulation.<sup>3</sup> With a proper feed inlet device to distribute the feed, the revamp simulation used an 82.5% tray efficiency for the three new trays. Superfrac trays, the highest combined efficiency and capacity cross-flow trays according to tests at the Fractionation Research Institute (FRI), use the follow-

ing features to increase tray efficiency:<sup>4</sup>

- Minivalve valves provide an increased number of vapour/liquid contact points to improve mass transfer efficiency over conventional valves
- Directional push valves prevent stagnant pools on the tray deck and reduce vapour maldistribution
- Multi-chordal downcomers promote even liquid distribution to the active area of the tray
- Balanced downcomer design handles froth and clear liquid zones, while increasing overall vapour handling capacity.

Figure 3 shows the Superfrac tray used in the revamp, and Figure 4 shows the revamp changes from an excerpt of the revised vessel elevation drawing.

A T-pipe feed distributor was chosen to reduce the serious liquid maldistribution occurring on the top tray. The T-pipe distributes the incoming liquid onto the centre inlet panel of the top tray. Inlet weirs on both sides of the centre inlet panel distribute the liquid evenly

Breakout of incremental ethane recovery calculated post-revamp		
	% of data points	Average in range
>5% C <sub>2</sub> recovery	8	6.0%
3–5% C <sub>2</sub> recovery	64	3.2%
<3% C <sub>2</sub> recovery	28	1.8%

**Table 3**

across the entire two-pass tray active area.

## Results

Revamp work was performed on the four units over five- to seven-day turnarounds during 2010–2011. The plants started up successfully without incident and performed with above-expected ethane recovery. Comprehensive test runs were performed to provide a comparison to pre-revamp data. Data were compared where inlet pressure, inlet flow and inlet gas composition were closest. The following factors were kept under specific control during the test runs for comparison purposes:

- Inlet pressure was matched within 2%
- Inlet flow and composition to unit were within 5%
- Ambient air temperature was matched within 5%.

Over 60 data points at each location were found that matched post- and pre-revamp operating conditions. The average incremental ethane recovery over the sample periods evaluated was 3%, matching the revamp simulation expectations. Table 2 shows the overall range of incremental ethane recovery results evaluated. Table 3 shows the distribution of ethane recoveries.

The overriding reason for the data points below the average expected ethane recovery after the revamp was a lower than average inlet pressure. As pressure is lowered, there is a decreased level of energy available to transform into refrigeration, so the benefit of the increased tray efficiency is not fully realised. Another option for revamp is to provide

booster compression to maintain a minimum inlet pressure at all times. This would capture the dual benefit of the trays, providing the expected incremental recovery and the gain in recovery from a higher pressure. For the cases where the average ethane recovery was greater than 5%, the inlet feed pressure was elevated, which allowed the separator temperature to be reduced for increased reflux to improve ethane recovery. The impact of this situation was an additional 2–2.5% ethane recovery. As a result, the overall ethane recovery translates to around a 3.5–4% increase from the revamped trays.

No incremental operating costs are needed for this type of revamp. The value gain (incremental revenue minus incremental cost) from the incremental ethane recovered quickly covers the cost of the revamp (equipment and installation) to create a payback of approximately three months.

There is room on the Superfrac

trays to increase flow by 15%. Other equipment around the tower limits an increased flow and provides the next debottlenecking opportunity.

### Conclusion

The incremental ethane production from this type of revamp project is consistently higher than anticipated, and the project has been considered a success at the four units with a payback of less than half a year. Three more revamps on Alberta-based demethanisers are planned to be executed by Koch-Glitsch for Q4 2011. The Inside-Out Design Approach used by Koch-Glitsch aimed to provide the project team with confidence in the gain in value proposed in recommendations for the tower internals revamp.

Other revamp options to further increase the ethane recovery of these entire facilities are also being considered.

Demister, Max-Frac, Minivalve and Superfrac are marks of Koch-Glitsch LP.

### References

- 1 Huang, *et al*, Processes for high C<sub>2</sub> recovery from LNG — part II: schemes based on expander technology, AIChE Spring National Meeting, Orlando, FL, 2006.
- 2 Remesat D, Inside-Out Design Approach, *Hydrocarbon Processing*, 2006.
- 3 Remesat D, Improving performance through low-cost modification of tower internals, *PTQ*, Q3 2010.
- 4 Nieuwoudt I, *et al*, Revamp & retune, *Hydrocarbon Engineering*, July 2009, 14, 7, 56–60.

**Darius Remesat** is a Process Consultant with Koch-Glitsch Canada, focusing on providing solutions to increase capacity, productivity and reliability of refining and petrochemical separation systems. He holds an MSc and PhD from the University of Calgary, Canada, MBA from Heriot-Watt University, UK, and BEng from McMaster University, Canada.

**Paul Wenger** is a Senior Plant Engineering Professional working for numerous midstream operators. He has been involved in numerous optimisation projects to improve overall asset utilisation and holds an engineering degree from the University of Calgary and MSc from the University of Victoria.