

KFBE

FLUIDIZED BED STRUCTURED PACKING

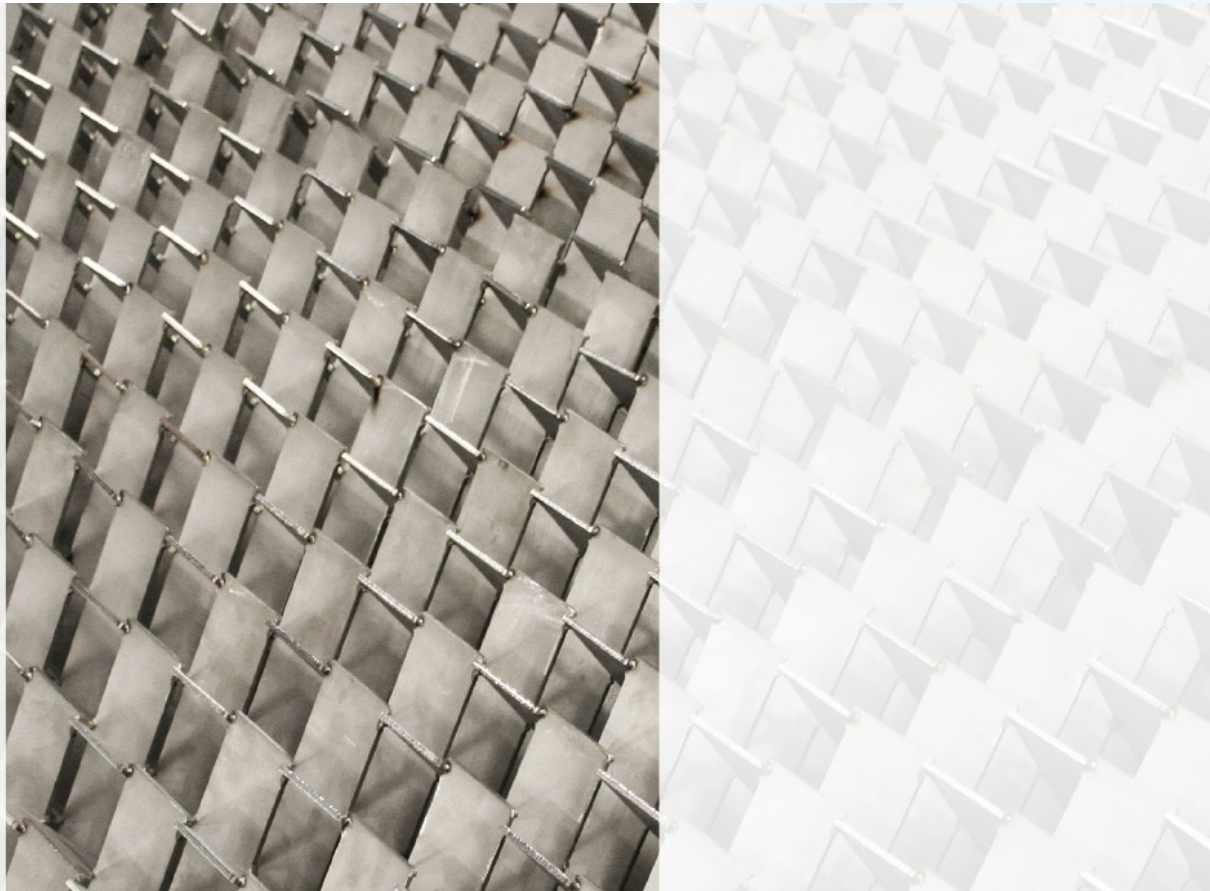

YOU CAN RELY ON US.

 **KOCH-GLITSCH™**

A KOCH ENGINEERED SOLUTIONS BUSINESS

HAVE YOU NOTICED THESE ISSUES WITH YOUR FCCU?

Hydrocarbon entrainment to the regenerator can lead to:

- ▼ Lower product recovery
- ▼ Elevated catalyst regenerator temperatures
- ▼ Reduced capacity, reliability, and operational flexibility
- ▼ Lower cat/oil ratios and reduced conversion

Excessive use of stripping steam can result in:

- ▼ Increased operational costs and burden to the utilities system
- ▼ Lower available capacity of the FCC main fractionator and its overhead condenser
- ▼ Excessive sour water discharge and increased costs in the Sour Water Stripper Unit

Excessive erosion of catalyst stripper internals can lead to:

- ▼ Costly and time consuming repairs
- ▼ Repeated cycles of damage and repairs
- ▼ Hot work at every turnaround

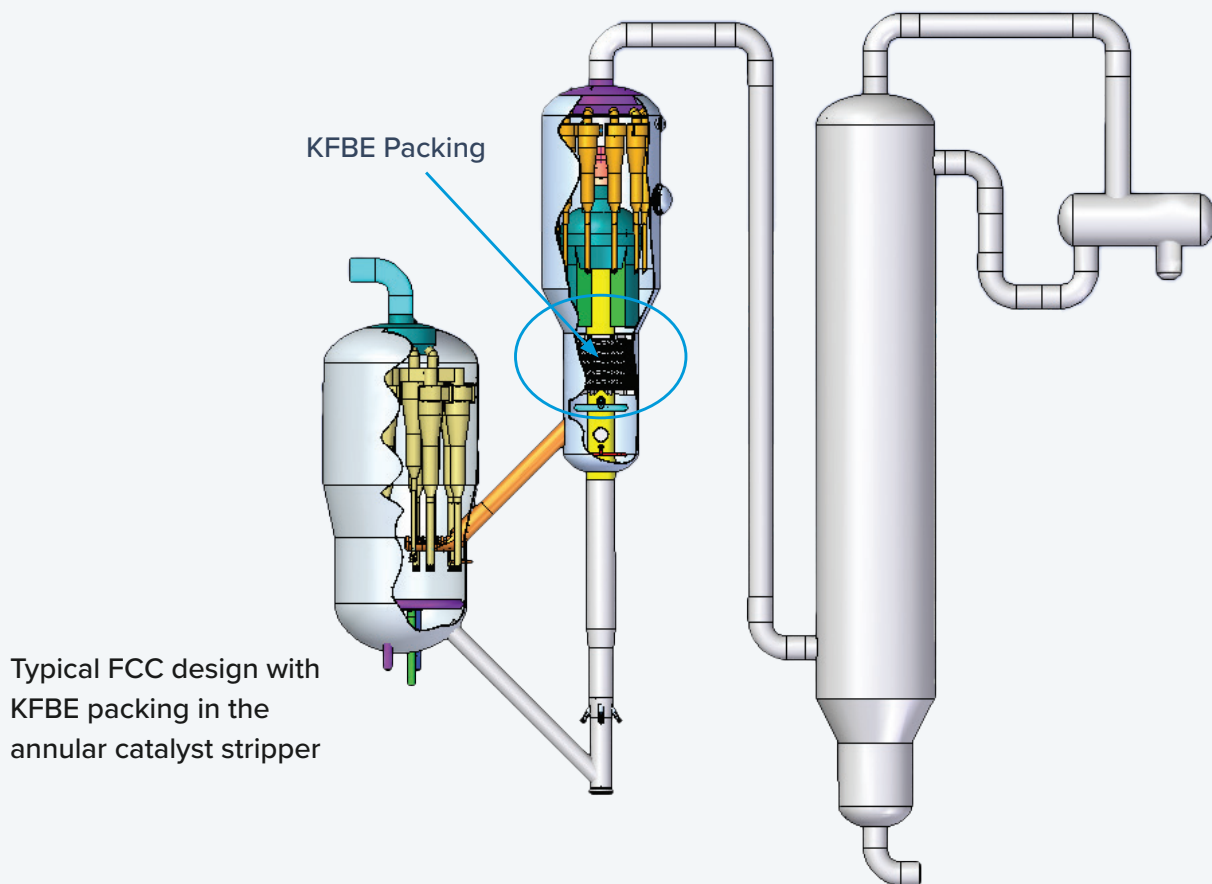

OTHER REFINERS HAVE HAD THE SAME ISSUES.

And found the key to unlocking the potential of their FCCU is in the catalyst stripper.

Repeated upgrading of the FCCU for higher capacity, heavier feeds, and improved yields has left many catalyst strippers with capacity and stripping efficiency constraints and erosion problems.

Trays Block 50% of the Vessel Area

REDUCES CAPACITY

- ▼ Constricts flow area in pinch points
- ▼ Allows catalyst defluidization directly above the tray

REDUCES EFFICIENCY

- ▼ Isolates contacting to small zones
- ▼ Allows channeling and bypassing

PROMOTES EROSION

- ▼ Catalyst and steam velocities are high
- ▼ Highest velocities at pinch points erode ends of and holes in trays

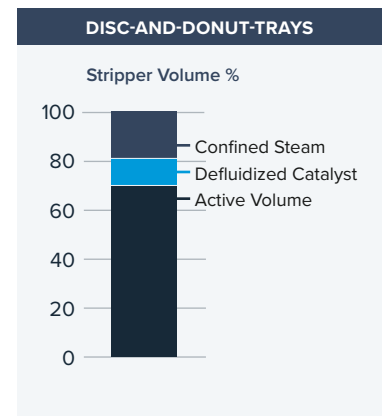
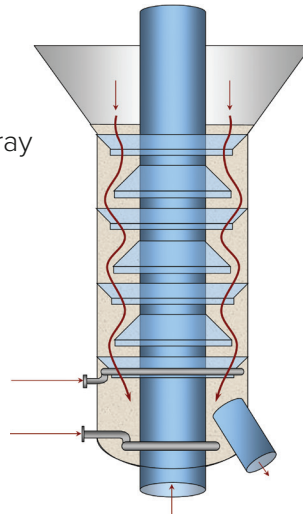

KFBE Packing Uses the Entire Vessel Volume

MAXIMIZES AVAILABLE CAPACITY

- ▼ Uses 95% of the vessel volume for process flow

MAXIMIZES UNIFORM RESIDENCE TIME

- ▼ Eliminates empty zones and stagnant zones of catalyst de-aeration
- ▼ Provides slow and uniform descent of catalyst through the stripper

IMPROVES STRIPPING EFFICIENCY

- ▼ Provides maximum catalyst residence time with low catalyst velocity
- ▼ Improves contact through smaller bubble size
- ▼ Reduces channeling and bypassing

REDUCES EROSION

- ▼ No pinch points of high velocity
- ▼ Low local velocities throughout entire bed

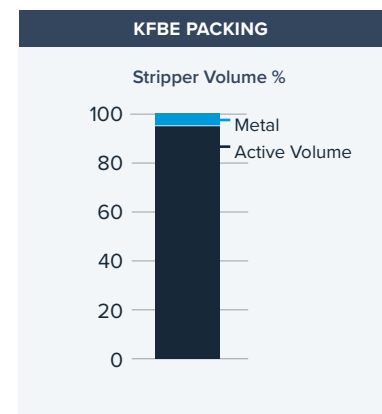
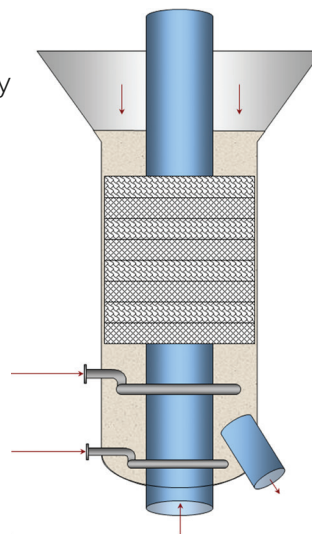

KFBE PACKING IS ENGINEERED FOR CATALYST STRIPPERS

Designed for the demanding needs of gas-solid fluidized bed systems, KFBE packing enhances gas-solid contact without restricting flow or allowing solids stagnation.

The rugged metal plates turn and break up the catalyst promoting uniform fluidization and slow, uniform descent of catalyst through the stripper. As steam rises in small turbulent bubbles, hydrocarbon is efficiently stripped. The durable construction is not susceptible to mechanical failure, and the open design resists coking.

Materials of Construction

The most commonly used material is 410S with low alloy support beams. Hotter regenerated catalyst applications frequently use 304H. Other materials are available depending on the specific design and customer request.

Multiple Sizes

KFBE packing is available in five sizes to accommodate various vessel designs. For all sizes, the stripping efficiency per layer is comparable. The packing size is selected to fit the available vessel height.

Size	Layer Height	Blade Width	Blade Spacing	Use
2A	10 in [254 mm]	Narrowest	Smallest	Pilot and specialty units
2B	12 in [305 mm]	↓	↓	Short available vessel height
2C	15 in [381 mm]			Standard size
2D	18 in [457 mm]	↓	↓	Excess available vessel height
2E	20 in [508 mm]			Widest

Flexible Design

KFBE packing is manufactured in layers that are contoured to fit any vessel configuration. Designs account for out-of-round tolerance on vessels as well as for thermal expansion. For older vessels with severely out-of-round shells or offcenter risers, measured dimensions can be used to design for proper fit.

ANNULAR AND FULL-CIRCLE UNITS

KFBE packing is used in both annular strippers (those with a reaction riser in the middle of the stripper) and full-circle strippers. In annular strippers, the packing, its support and its hold-down do not touch the reaction riser.

COLD AND HOT WALL UNITS

KFBE packing is used in both cold wall and hot wall catalyst strippers. Shell attachments can be welded to the shell behind thermal refractory, abrasion lining, or no lining.

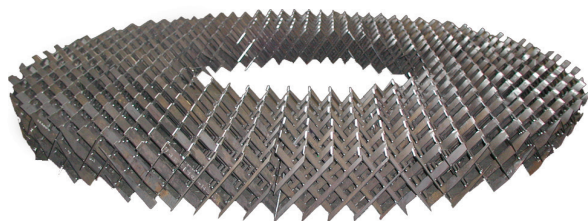

ANNULAR KFBE PACKING FOR INSTALLATION AROUND THE REACTION RISER

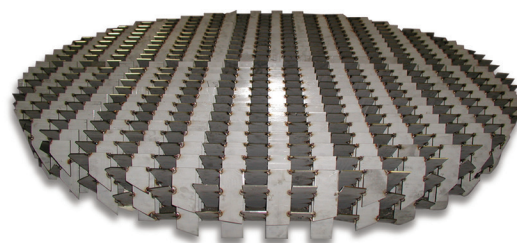

FULL-CIRCLE KFBE PACKING LAYER FOR VESSELS WITH EXTERNAL RISERS

KFBE PACKING OPTIMIZES STRIPPING PERFORMANCE

Robust and efficient, KFBE packing provides ease of installation and operating flexibility for retrofits and new installations.

Installation is easy and can be accommodated during most FCC maintenance schedules. Each block of KFBE packing fits through the vessel manways. Outer blocks are manufactured contoured to the stripper wall.

Robust and Durable Construction

- ▼ Resists mechanical failure in the normally hot, erosive service
- ▼ Withstands normal handling without damage
- ▼ Promotes reuse of packing through multiple campaigns

Easy Installation, Replacement and Maintenance

- ▼ Shell attachments are one-time installation
- ▼ Installation of removable equipment takes hours or shifts, rather than days or weeks
- ▼ Allows easy removal for safe and unconstrained access during vessel inspection and maintenance
- ▼ Provides easy reinstallation
- ▼ Designed for out-of-round vessel tolerance and can be trimmed for excessive out-of-round or refractory bulges

Reduces Number of Permanent Vessel Shell Attachment

- ▼ Removable support grids, packing and hold-down grids
- ▼ Support attachments are above and below the packing, not within the packed bed
- ▼ Support attachments can be given greater corrosion/erosion allowance

Maximizes Use of Vessel Height

- ▼ Bed depths of 8 to 12 ft [2.4 to 3.6 m] are common
- ▼ Bed depths of 6 ft [1.8 m] can strip effectively

Maximizes Catalyst Stripping

- ▼ Least hydrocarbon lost to regenerator
- ▼ Lowest regenerator temperature; highest cat-to-oil ratio
- ▼ Fluidization maintained through the stripper for maximum head gain, often 39 lb/ft³ [625 kg/m³]
- ▼ Steam consumption as low as 2 lb/Mlb [2 kg/t] of catalyst
- ▼ Corresponding lower discharge of sour water

Avoids Erosion in Stripper

- ▼ Packing avoids pinch zones where catalyst and steam accelerate and pass through each other
- ▼ Local catalyst and steam velocities are low and uniform
- ▼ Packing allows high catalyst flux and/or high steam rate without erosion

KFBE PACKING IS PROVEN TECHNOLOGY

With proven performance and reliability, KFBE packing has been installed in more than 80 catalyst strippers and 14 other FCC vessels.

With original installations in operation more than 15 years, none of the installed units have experienced coking. All installations continue operating with KFBE packing.

Premiere Catalyst Stripper Technology

- ▼ Combined 500 years of operation experience
- ▼ Diameters up to 25 ft [7.6 m]
- ▼ Approximately half the units crack resid
- ▼ More than 10 units are designed for on-purpose propylene
- ▼ Design temperatures up to 1148°F [620°C] in spent catalyst strippers
- ▼ Design temperatures up to 1500°F [816°C] in regenerated catalyst vessels
- ▼ More than 3.9 MM bbl/d installed FCC capacity

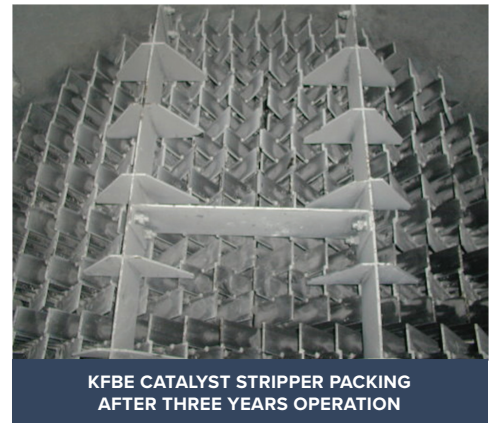

KFBE PACKING PROVIDES A SHORT PAYBACK

Customers who have upgraded to KFBE packing have realized significant benefits.

Reliability project pays out in under 6 months

A refinery replaced a shed deck design with KFBE packing to reduce stripping steam and avoid ongoing maintenance issues. Applying KFBE packing reduced stripping steam use by 50%, increased available capacity in the main fractionator, and reduced sour water discharge to the sour water unit. The reduction in sour water allowed the refiner to avoid a capacity revamp in the sour water unit. Although the project was aimed at unit reliability, payout was less than 6 months.

Conversion increase project pays out in under 3 months

A small catalyst stripper caused FCCU capacity and feed limitations. Mechanical and structural constraints prevented the refinery from considering a larger catalyst stripper. Revamping with KFBE packing reduced

hydrocarbon product loss to the regenerator, lowered regenerator operating temperature, and increased head gain over the spent catalyst line. The combined effect of these improvements allowed the refiner to increase catalyst circulation by 5%, increasing conversion by 3-5% depending on the feedstock. Payout of the project was less than 3 months.

Operation constraints revamp pays out in under 60 days

Poor catalyst stripping was causing excessive catalyst regeneration temperatures. Revamping the stripper with KFBE packing allowed use of the existing catalyst stripper vessel, reduced the temperature in the regenerator dense bed catalyst by 50°F, virtually eliminated after-burn in the regenerator and reduced stripping steam use by 40%. The higher cat/oil ratio improved unit conversion by 3%. Payout for the revamp was less than 60 days.

IF YOU THINK WE CAN HELP, LET'S TALK

KFBE packing is available through Koch-Glitsch Authorized Licensors, TechnipFMC and Axens, or directly from Koch-Glitsch.

Koch-Glitsch is proud to offer its packed catalyst stripper technology in partnership with TechnipFMC and Axens, which are both world leaders in FCC technology. KFBE packing technology from Koch-Glitsch is licensed through its technology partners or is available directly from Koch-Glitsch.

Work with Koch-Glitsch's licensors to receive:

- ▼ Yield forecasts
- ▼ Process guarantees
- ▼ Project management
- ▼ Mechanical reviews
- ▼ Process safety reviews
- ▼ P&ID reviews
- ▼ Start-up support
- ▼ FCCU troubleshooting
- ▼ Additional FCC technologies

Improve stripper performance and unlock the potential of your FCCU

- ▼ Increase stripper capacity
- ▼ Improve hydrocarbon recovery
- ▼ Improve catalyst circulation
- ▼ Improve operational flexibility
- ▼ Reduce regenerator operating temperatures
- ▼ Reduce stripping steam requirement
- ▼ Reduce sour water discharge

Work directly with Koch-Glitsch if you need:

- ▼ Mechanical design
- ▼ Equipment supply
- ▼ Field installation

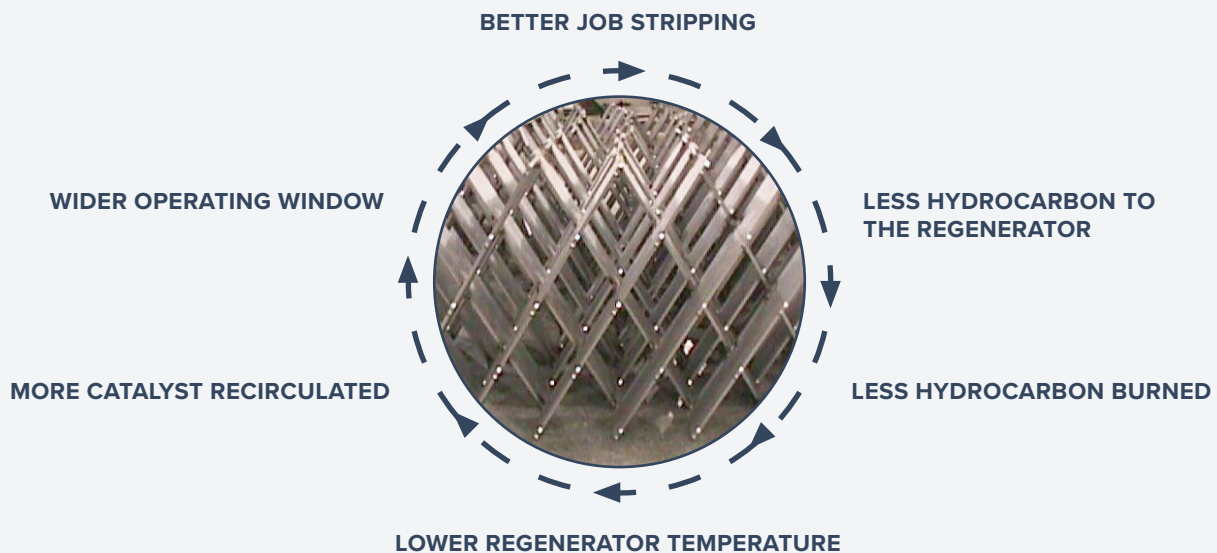



TechnipFMC

Director, FCC Technology tel: (1) 281-870-1111
11740 Katy Freeway fax: (1) 281-249-8899
Houston, TX 77079 USA technipfmc.com/en/contact-us



Axens

R2R & FCC Technology Manager tel: +33 1 47 14 24 54
89 Boulevard Fanklin Roosevelt BP 50802 fax: +33 1 47 14 25 00
95208 Rueil-Malmaison - Cedex, France axens.com

KOCH-GLITSCH MAIN OFFICES

Koch-Glitsch, LP

4111 East 37th Street North
Wichita, Kansas 67220

tel: (1) 316-828-5110
fax: (1) 316-828-7985
info.wichita@kochglitsch.com

Emergency Hotlines

+1-888-562-4911 (mass transfer)
+1-316-207-7935 (mist elimination)

Koch-Glitsch Italia S.r.l.

Via Torri Bianche, 3A 20871
Vimercate MB Italy

tel: +39 039 6386010
fax: +39 039 6386011
info.vimercate@kochglitsch.com

Emergency Hotlines

+39-06-928-911
+44-1782-744561

Koch Engineered Solutions Singapore Pte. Ltd.

260 Orchard Road, #11-01/09
The Heeren
SINGAPORE 238855

tel: +65-6831-6500
fax: +65-6835-2031
info.singapore@kochglitsch.com

Emergency Hotlines

+65-6831-6500



For a complete list of our
offices and facilities,
visit koch-glitsch.com.

Trademarks

The following registered trademarks are owned by Koch-Glitsch, LP in the United States and may be registered in other jurisdictions. KOCH-GLITSCH and "K" KOCH-GLITSCH. The following trademarks are owned by Koch-Glitsch, LP in the United States and may be registered in other jurisdictions: KFBE and YOU CAN RELY ON US. All other trademarks, service marks, or registered trademarks that appear in this document are the trademarks or service marks of their respective owners. For related trademark information, visit www.koch-glitsch.com/legal-notices/trademarks.

Legal Notice: The information contained in this bulletin is believed to be accurate and reliable, but is not to be construed as implying any warranty or guarantee of performance. Bulletin KFBE-02. Printed in USA. ©2025 Koch-Glitsch, LP. All Rights Reserved.