

## FyrBolt FP Gas Igniter

### Reliable Performance For Maximum Uptime

A single igniter failure can bring your operations to a sudden, expensive halt. That's why we design our high-energy gas igniters to provide safe and reliable performance for boiler burner operation in even the harshest conditions. At our Research and Development Test Center, the largest and most advanced testing complex of its kind, our igniters have operated reliably in the most severe combustion conditions.

#### FyrBolt FP Igniter Features

Easier to install and able to light instantly even in wet conditions, FyrBolt FP igniters come back online faster, saving you time and money. Other FyrBolt FP features and benefits include:

- + Durable mechanical design with stainless steel parts to minimize corrosion and deliver a longer service life
- + Easy to retrofit for existing burners
- + Robust, stable flame ensures burner ignition and flame detection
- + No augmenting air required, for most applications

#### High-energy Ignition Benefits

FyrBolt FP igniters also offer the benefits of high-energy ignition:

- + Ignition probe is unaffected by high moisture and dusty environments
- + Powerful capacitance discharge spark provides more reliable ignition than a conventional spark plug igniter
- + A fixed / non-adjustable spark gap ensures proper installation and reliable spark
- + Compatible with flame rod
- + Built in predictive life diagnostics
- + Certified for use in hazardous areas

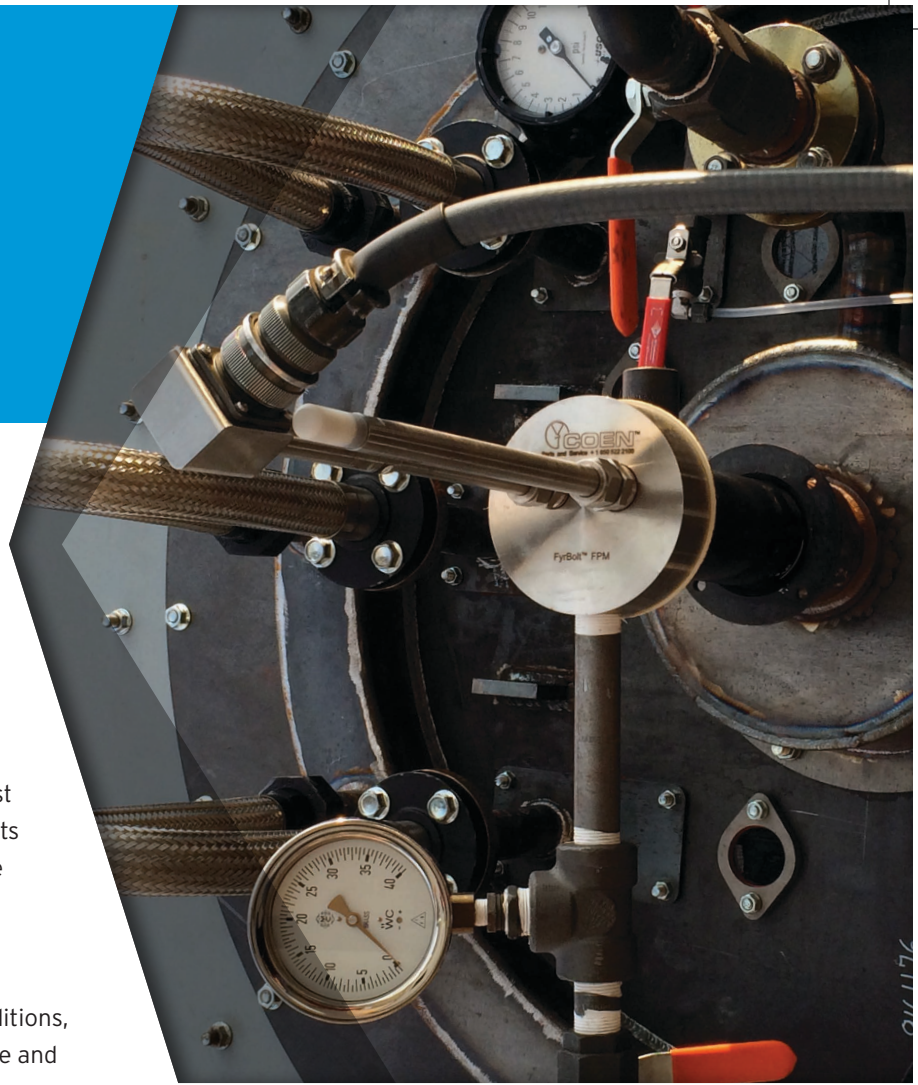

*Our John Zink®, Coen®, Todd®,  
Hamworthy Combustion®, and Peabody®  
brands increase service life, minimize  
downtime and reduce operating costs.  
**That's smart. That's JZHC.***



## Specifications

**Fuel Type:** Natural Gas\*, Propane\*

**Heat Input:** 0.75 MMBtu/hr (250 KW) - 2.0 MMBtu/hr (750 KW)

**Igniter Class:** NFPA Class 3

**Igniter Duty:** Interruptible

**Gas Pressure Required at Igniter:** 1 psig (0.07 bar) minimum

**Input Power:** 100 - 240 VAC / 50 - 60 HZ

**Spark Rate:** 4 Joules / 15 Sparks-per-Second

\*Can operate with other fuels - Consult factory.

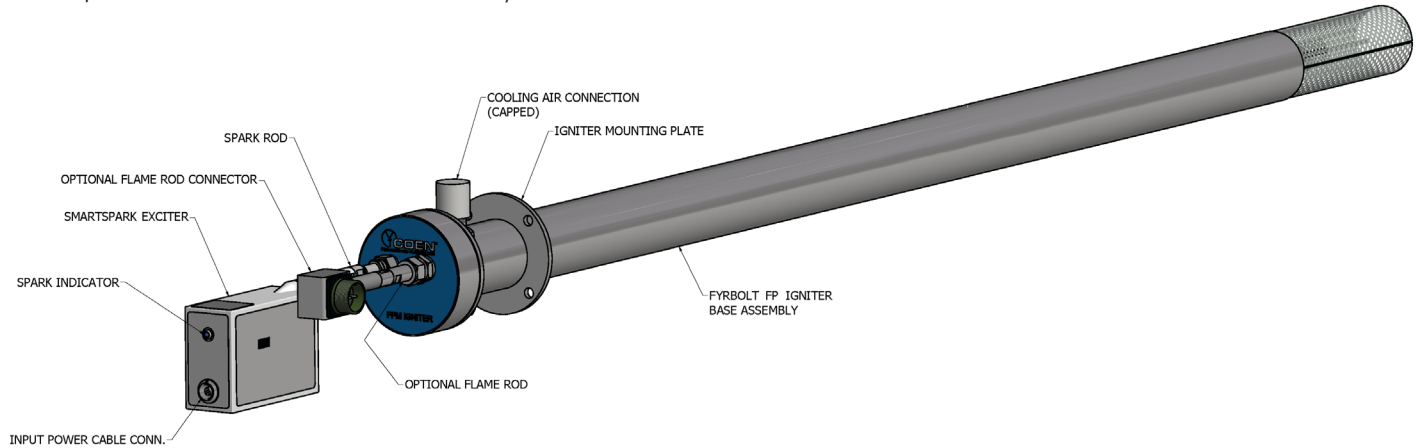

### GLOBAL REACH

JZHC has locations all over the map,  
with thousands of employees worldwide.



#### Global Headquarters

Tulsa, Oklahoma | United States

[johnzinkhamworthy.com](http://johnzinkhamworthy.com) | +1 918 234 1800

To locate an office in your region, visit [johnzinkhamworthy.com/contacts/office-locator](http://johnzinkhamworthy.com/contacts/office-locator)